



## AGENDA

Orange County Council of Governments  
Board of Directors Meeting

Orange County Council of Governments

August 26, 2021

As set forth in Orange County Council of Governments Bylaws and Joint Powers Agreement - the Orange County Council of Governments is a voluntary agency established to serve as a sub- regional organization to the Southern California Association of Governments representing Orange County on mandated and non-mandated regional planning activities, to provide a vehicle for Members to engage cooperatively on such activities, and to conduct studies and projects designed to improve and coordinate common governmental responsibilities and services on an area-wide and regional basis.

**Pursuant to Executive Order N-29-20 issued on March 17, 2020, by Governor Gavin Newsom, which directs Californians to follow public health directives including canceling large gatherings, certain provisions of the Ralph M. Brown Act are suspended due to a State of Emergency in response to COVID-19. Consistent with the Executive Order, OCCOG Board meetings will be conducted by teleconference only. Those persons wishing to speak on any item included on the agenda, or on any matter within the subject matter jurisdiction of the OCCOG Board, are invited to submit electronic written comments to [kathryn@occog.com](mailto:kathryn@occog.com). If you do not have access to email, you may also call the Board Clerk at (949) 357-3342 before 9:00 a.m. on August 26, 2021, to submit your comments over the phone.**

**If you would like to participate and speak via the teleconference, please use the following URL:**

Join Zoom Meeting

<https://us06web.zoom.us/j/85217849017>

Meeting ID: 852 1784 9017

One tap mobile

+13462487799,,85217849017# US (Houston)

Dial by your location

+1 669 900 6833 US (San Jose)

Meeting ID: 852 1784 9017

Find your local number: <https://us06web.zoom.us/j/85217849017>

**In compliance with the Americans with Disabilities Act, if you require a reasonable accommodation to participate in this meeting, please contact the Board Clerk at (949) 357-3342 at least 48 hours prior to the advertised starting time of the meeting.**

**Any documents produced by the Board and distributed to a majority of the Board regarding any item on this agenda will be posted on the Board's website at <https://www.occog.com/>.**

**For all other questions, please call the Board Clerk at (949) 357-3342.**



### Zoom Format Only

1 (669) 900-6833 Meeting ID Number 871 6280 1914

Password 300182 - 10:30 a.m. to 12:00 p.m.

#### Board Members (Voting)

**District 19** Chairman Trevor O'Neil

**District 13** Vice Chair Wendy Bucknum

**District 12** Fred Minagar

**District 14** Michael Carroll

**District 15** Diane Dixon

**District 16** Phil Bacerra

**District 17** Letitia Clark

**District 18** Kim Nguyen

**District 20** Joe Kalmick

**District 21** Art Brown

**District 22** Marty Simonoff

**District 64** Mike Posey

**County of Orange SCAG Representative** Donald Wagner

**Cities-at-Large** Rose Espinoza

**Independent Special Districts of Orange County (ISDOC)** Mike Scheafer

**Orange County Sanitary District (OCSD)** David Shawver

**Orange County Transportation Authority (OCTA)** Brian Goodell

**South Coast Air Quality Management District (SCAQMD)** Carlos Rodriguez

**Transportation Corridor Agency (TCA)** Scott Voigts

#### Ex-Officio Members (Non-Voting)

**Anaheim Resort Transportation (ART) (Ex-Officio)** Diana Kotler

**Association of California Cities, Orange County (ACC-OC) (Ex-Officio)** Bruce Channing

**Business Community (OCBC) (Ex-Officio)** Jennifer Ward

**Caltrans District 12** Ryan Chamberlain

**League of California Cities, Orange County, (LOCC-OC) (Ex-Officio)** Tony Cardenas

**Orange Co. Local Agency Formation Commission (OC-LAFCO) (Ex-Officio)** Carolyn Emery

**Non-Profit Housing Community (Ex-Officio)** Helen O'Sullivan

**Private Sector (Ex-Officio)** Steven LaMotte

**University Community (Ex-Officio)** Amanda Hughes

#### Vacant

**County-at-Large**

**Health Care/Hospital Industry**



### **Agenda Descriptions**

The agenda descriptions are intended to provide members of the public a general summary of items of business to be transacted or discussed. The posting of the recommended actions does not indicate what action will be taken. The Board of Directors may take any action deemed to be appropriate and is not limited by the notice of the recommended action.

### **Public Comments on Agenda Items**

Members of the public wishing to address the Board of Directors regarding any item appearing on the agenda may do so by completing a Speaker Card and submitting it to the Clerk of the Board. Speakers will be recognized by the Chair at the time the agenda item is considered. A speaker's comments shall be limited to three minutes.

### **Public Availability of Agenda Materials**

All documents relative to the items referenced in this agenda are available for public inspection at [www.occog.com](http://www.occog.com)

### **Accessibility**

Any person with a disability requiring a modification or accommodation in order to participate in this meeting should contact the Clerk of the Board at (949) 357-3342, no less than three business days prior to this meeting to enable the Orange County Council of Governments to make reasonable arrangements to assure accessibility to this meeting.

### **Call to Order**

### **Roll Call**

### **Pledge of Allegiance**

### **Public Comments**

Members of the public may address the Board of Directors regarding any items within the subject matter jurisdiction of the Board of Directors; however, action may not be taken on matters that are not listed on the agenda unless authorized by law. Comments shall be limited to three minutes per speaker, unless different time limits are set by the Chairman, subject to the approval of the Board of Directors.



### Consent Calendar (Item Nos. 1 - 3)

All matters listed under the Consent Calendar are routine and will be enacted by one vote without separate discussion unless Members of the Board, the public, or staff request specific items be removed for separate action or discussion.

**1. Approval of Meeting Minutes for June 24, 2021, Regular Meeting**

Kathryn Morrison, OCCOG Clerk of the Board

**Recommended Action:** *Receive and file the minutes as amended or presented.*

**2. OCCOG Financial Reports for June and July of 2021**

John Hanson, OCCOG Treasurer

**Recommended Action:** *Approve the OCCOG Financial Reports for June and July of 2021.*

**3. Auditor Letter of Communication to Board of Directors**

John Hanson, OCCOG Treasurer

**Recommended Action:** *Receive and file.*

### OCCOG Leadership Reports

**4. Chair Report**

Trevor O'Neil, OCCOG Chair

**5. Executive Director Report**

Marnie O'Brien Primmer, Executive Director

### Action Items

**6. OCCOG Voting Board Member Stipend Policy**

Marnie O'Brien Primmer, OCCOG Executive Director

**Recommended Action:** *Approve the Stipend Policy as presented or amended.*

**7. Legislative Update**

Wendy Strack, OCCOG Legislative Consultant

**Recommended Action:** *Approve the following recommended positions on legislation: Oppose AB 339, Support AB 361, Oppose AB 672, and Oppose AB 989.*



**Discussion Items**

**8. Update on Regional Early Action Planning (REAP) Grant Sub-regional Partnership Program**

Marnie Primmer, OCCCOG Executive Director

**Recommended Action:** Receive and File.

**9. Strategic Planning: Consideration of Governance Model(s).**

Marnie Primmer, OCCCOG Executive Director and Kris Murray, KLM Strategies, OCCCOG Consultant

**Recommended Action:** Receive and file. Provide additional direction to staff as needed.

**Presentations**

**10. Southern California Edison Charge Ready Program**

Shant Nahapetian, SCE Government Relations Senior Advisor, Southern California Edison

**11. Presentation on Proposition 1 IRWM Round 2 Grant from Santa Ana Watershed Project Authority**

Mark Norton from SAWPA and Chris Crompton of OC Public Works

**Brief Reports**

This section is set aside for brief reports or presentations from listed agencies. Speakers are requested to keep their comments brief. Any speaker wishing to provide a more detailed discussion should request the discussion be placed on the agenda at a future meeting.

- **OCCCOG Technical Advisory Committee**  
Nate Farnsworth, Technical Advisory Committee Chair
- **Southern California Association of Governments**  
Jonathan Hughes, Regional Affairs Officer, SCAG
- **South Coast Air Quality Management District**  
Carlos Rodriquez, OCCCOG Director; Debra Ashby, Senior Public Information Specialist  
SCAQMD; Link to May/June/July edition of SCAQMD Advisor Newsletter:  
<http://www.aqmd.gov/home/research/publications/advisor-archive/current-edition>
- **Board Member Reports**
- **Member Agency Reports**
- **Staff Member Reports**



### Call to Order

Chair O'Neil called the Regular Meeting of the Orange County Council of Governments to order at 10:32 a.m. on Thursday, June 24, 2021, via Zoom; at (669) 900 6833, Meeting ID Number 996 9252 0673.

### Board Members Present

**District 19** Chairman Trevor O'Neil

**District 13** Vice Chair Wendy Bucknum

**District 12** Fred Minagar

**District 14** Michael Carroll

**District 15** Diane Dixon

**District 16** Phil Bacerra

**District 17** Letitia Clark

**District 18** Kim Nguyen

**District 20** Joe Kalmick

**District 22** Marty Simonoff

**District 22** Ward Smith (Alternate)

**District 64** Mike Posey

**Cities-at-Large** Rose Espinoza

**Orange County Sanitary District (OCSD)** David Shawver

**Orange County Transportation Authority (OCTA)** Brian Goodell

**Anaheim Resort Transportation (ART) (Ex-Officio)** Diana Kotler

**Association of California Cities, Orange County (ACC-OC) (Ex-Officio)** Jenn Lowe (Alternate)

**Business Community (OCBC) (Ex-Officio)** Jennifer Ward

**Caltrans District 12 (Ex-Officio)** Chris Flynn (Alternate)

**League of California Cities, Orange County, (LOCC-OC) (Ex-Officio)** Tony Cardenas

**Non-Profit Housing Community (Ex-Officio)** Helen O'Sullivan

**Private Sector (Ex-Officio)** Steven LaMotte

**University Community (Ex-Officio)** Amanda Hughes

### Board Members Absent

**District 21** Art Brown

**Transportation Corridor Agency (TCA)** Scott Voigts

**South Coast Air Quality Management District (SCAQMD)** Carlos Rodriguez

**Orange Co. Local Agency Formation Commission (OC-LAFCO) (Ex-Officio)** Carolyn Emery

**Independent Special Districts of Orange County (ISDOC)** Mike Scheafer

### Board Vacancies

**Health Care/Hospital Industry (Ex-Officio)**



## MINUTES

Thursday, June 24, 2021 | 10:30 a.m.

### Staff Present

Marnie O'Brien Primmer, Executive Director  
Fred Galante, General Counsel  
Nate Farnsworth, TAC Chair  
Justin Equina, TAC Vice Chair  
Wendy Strack, OCCOG Legislative Consultant  
Lisa Telles, Consultant  
Eileen White, Clerk of the Board  
Kathryn Morrison, Administrative Assistant

### Others Present

Debra Ashby, Sr. Public Info Spec., SCAQMD  
Deborah Diep, Center for Demographic Research Director  
Gail Shiomoto-Lohr, City of Mission Viejo  
Jonathan Hughes, SCAG Public Affairs Officer  
Marika Poynter, Principal Planner, City of Irvine  
Mark Monin, ISDOC (Alternate)

**Pledge of Allegiance** led by Director David Shawver

**Public Comments** None

### Announcement of Closed Session

Fred Galante, General Counsel, recommended the Board recess into closed session to confer with Counsel on the one item of anticipated litigation under the heading of initiation of litigation, as described in the agenda.

### Recess to Closed Session

Chair O'Neil recessed the OCCOG Regular Meeting to the Closed Session at 10:36 a.m.

### Closed Session Call to Order

Chair O'Neil called the Closed Session to order at 10:38 a.m. via Zoom, Meeting ID 923 2573 1541.

### Directors Present

Trevor O'Neil (Chair), Wendy Bucknum (Vice-Chair), Phil Bacerra, Michael Carroll, Letitia Clark, Diane Dixon, Rose Espinoza, Brian Goodell, Joe Kalmick, Fred Minagar, Kim Nguyen, Mike Posey, Carlos Rodriguez, Ward Smith

### Directors Absent

Art Brown, Carlos Rodriguez, Scott Voigts



## MINUTES

Thursday, June 24, 2021 | 10:30 a.m.

### Staff Present

Executive Director Marnie O'Brien Primmer, Attorney Fred Galante, TAC Chair, Nate Farnsworth, TAC Vice Chair Justin Equina, Consultant Kristine Murray, Consultant Wendy Strack, City of Irvine, Principal Planner Marika Poynter, Board Clerk Eileen White, Administrative Assistant Kathryn Morrison

### Closed Session

- 1. CONFERENCE WITH LEGAL COUNSEL--ANTICIPATED LITIGATION** Fred Galante, OCCOG General Counsel  
Initiation of litigation pursuant to paragraph (4) of subdivision (d) of Section 54956.9.  
Number of cases: One case

### Return to Regular Meeting

Chair O'Neil recessed the Closed Session at 11:20 a.m. and reconvened the Regular Meeting at 11:50 a.m. with the Directors remaining in attendance.

### Announcement of Closed Session Action

General Counsel Fred Galante announced that the Board received an update to the status of the initiation of litigation matter, that the matter has since been filed under the caption of OCCOG v. Gustavo Velasquez, in his official capacity, and the California Dept. of Housing and Community Development and that no further reportable action was taken.

### Consent Calendar (Item Nos. 1-5)

- 1. Approval of Meeting Minutes for May 27, 2021, Regular Meeting** Eileen White, OCCOG Clerk of the Board  
It was moved by Director Posey and seconded by Director Carroll to receive and file the minutes as presented. Said motion was carried by the following vote:  
  
AYES: (14) BUCKNUM, CARROLL, CLARK, DIXON, ESPINOZA, GOODELL, KALMICK, MINAGAR, NGUYEN, O'NEIL, POSEY, RODRIGUEZ, SHAWVER, SMITH  
NOES: (0)  
ABSTAINING: (0)  
ABSENT: (4) BROWN, RODRIGUEZ, SCHAEFER, VOIGTS
- 2. OCCOG Financial Reports for June 2021** John Hanson, OCCOG Treasurer  
It was moved by Director Posey and seconded by Director Carroll to approve the Financial Reports for June 2021. Said motion was carried by the following vote:





AYES: (14) BUCKNUM, CARROLL, CLARK, DIXON, ESPINOZA, GOODELL, KALMICK, MINAGAR, NGUYEN, O'NEIL, POSEY, RODRIGUEZ, SHAWVER, SMITH

NOES: (0)

ABSTAINING: (0)

ABSENT: (4) BROWN, RODRIGUEZ, SCHAEFER, VOIGTS

**3. Investment Policy** Marnie O'Brien Primmer, Executive Director; John Hanson, Treasurer

**Recommended Action:** Approve the statement of investment policy as presented or amended.

It was moved by Director Posey and seconded by Director Carroll to approve the Investment Policy for June 2021. Said motion was carried by the following vote:

AYES: (14) BUCKNUM, CARROLL, CLARK, DIXON, ESPINOZA, GOODELL, KALMICK, MINAGAR, NGUYEN, O'NEIL, POSEY, RODRIGUEZ, SHAWVER, SMITH

NOES: (0)

ABSTAINING: (0)

ABSENT: (4) BROWN, RODRIGUEZ, SCHAEFER, VOIGTS

**4. Legislative Update**

Wendy Strack, OCCOG Legislative Consultant

**Recommended Action:** *Receive and file Legislative Update*

It was moved by Director Posey and seconded by Director Carroll to receive and file the minutes as presented. Said motion was carried by the following vote:

AYES: (14) BUCKNUM, CARROLL, CLARK, DIXON, ESPINOZA, GOODELL, KALMICK, MINAGAR, NGUYEN, O'NEIL, POSEY, RODRIGUEZ, SHAWVER, SMITH

NOES: (0)

ABSTAINING: (0)

ABSENT: (4) BROWN, RODRIGUEZ, SCHAEFER, VOIGTS

**5. Memoranda of Understanding with Orange County Housing Finance Trust and Orange County Housing Trust for Regional Early Action Planning Grant**

Fred Galante, General Counsel

**Recommended Action:** *Approve the MOU's for REAP projects with OCHT and OCHFT as presented or amended.*



It was moved by Director Posey and seconded by Director Carroll to approve the MOU's for REAP projects with OCHT and OCHFT. Said motion was carried by the following vote:

AYES: (14) BUCKNUM, CARROLL, CLARK, DIXON, ESPINOZA, GOODELL, KALMICK, MINAGAR, NGUYEN, O'NEIL, POSEY, RODRIGUEZ, SHAWVER, SMITH

NOES: (0)

ABSTAINING: (0)

ABSENT: (4) BROWN, RODRIGUEZ, SCHAEFER, VOIGTS

**Action Items**

**6. Approve OCCOG Fiscal Year 2021-22 Budget**

Marnie O'Brien Primmer, OCCOG Executive Director

**Recommended Action:** *Approve the OCCOG fiscal year 2021-22 Work Plan as presented or amended.*

It was moved by Director Posey and seconded by Director Wendy Bucknum to approve the OCCOG fiscal year 2021-22 budget.

AYES: (14) BUCKNUM, CARROLL, CLARK, DIXON, ESPINOZA, GOODELL, KALMICK, MINAGAR, NGUYEN, O'NEIL, POSEY, RODRIGUEZ, SHAWVER, SMITH

NOES: (0)

ABSTAINING: (0)

ABSENT: (4) BROWN, RODRIGUEZ, SCHAEFER, VOIGTS

**7. Approve OCCOG Fiscal Year 2021-22 Work Plan**

Marnie O'Brien Primmer, OCCOG Executive Director

**Recommended Action:** *Approve the OCCOG Fiscal year 2021-22 Work Plan as presented or Amended.*

It was moved by Director Posey and seconded by Director Wendy Bucknum to approve the OCCOG fiscal year 2021-22 work plan.

AYES: (14) BUCKNUM, CARROLL, CLARK, DIXON, ESPINOZA, GOODELL, KALMICK, MINAGAR, NGUYEN, O'NEIL, POSEY, RODRIGUEZ, SHAWVER, SMITH

NOES: (0)

ABSTAINING: (0)

ABSENT: (4) BROWN, RODRIGUEZ, SCHAEFER, VOIGTS



## MINUTES

Thursday, June 24, 2021 | 10:30 a.m.

8. **FY 2021-22 Contract Renewals for Connected Consulting, Executive Director Services; Aleshire & Wynder LLC, General Counsel; Kathryn Morrison, Clerk of the Board; Wendy J Strack Consulting, OCCOG Legislative Consultant; Lisa Telles, Project Management and Communications Consultant; John Hanson, Treasurer; and KLM Strategies, Strategic Advisement**

Fred Galante, OCCOG General Counsel and Marnie O'Brien Primmer, Executive Director

**Recommended Action:** *Approve Contract Renewals as submitted or revised.*

9. **Contract for FY 2021-22 Marketing and Communications Services with AJ Design** Marnie O'Brien Primmer, OCCOG Executive Director

**Recommended Action:** *Approve Contract for AJ Design as submitted or revised.*

10. **Approve Letter for Vehicles Miles Traveled Relief Letter**

Marnie O'Brien Primmer, OCCOG Executive Director

**Recommended Action:** *Approve letter as presented or amended.*

It was moved by Director Posey and seconded by Director Carroll to approve the Vehicle Miles Traveled Relief Letter. Said motion was carried by the following vote:

AYES: (14) BUCKNUM, CARROLL, CLARK, DIXON, ESPINOZA, GOODELL, KALMICK, MINAGAR, NGUYEN, O'NEIL, POSEY, RODRIGUEZ, SHAWVER, SMITH

NOES: (0)

ABSTAINING: (0)

ABSENT: (4) BROWN, RODRIGUEZ, SCHAEFER, VOIGTS

11. **Approve SONGS Coalition Letter**

Marnie O'Brien Primmer, Executive Director

**Recommended Action:** Approve Letter as presented or amended.

It was moved by Vice Chair Bucknum and seconded by Director Shawver to approve the SONGS Coalition Letter. Said motion was carried by the following vote:



AYES: (14) BUCKNUM, CARROLL, CLARK, DIXON, ESPINOZA, GOODELL, KALMICK, MINAGAR, NGUYEN, O'NEIL, POSEY, RODRIGUEZ, SHAWVER, SMITH

NOES: (0)

ABSTAINING: (0)

ABSENT: (4) BROWN, RODRIGUEZ, SCHAEFER, VOIGTS

**12. Resolution 2021-01 Approving County of Orange Return to OCCOG**

Marnie O'Brien Primmer, OCCOG Executive Director

**Recommended Action:** *Approve Resolution 2021-01 Readmitting the County of Orange as a Member in good standing to the Orange County Council of Governments.*

**Discussion Items**

**13. Strategic Planning – OCCOG Governance Models**

Kris Murray, KLM Strategies, OCCOG Consultant

Discussion ensued regarding strategic planning of the OCCOG Governance Models. Items of note included exploring new governance orders that would better serve Orange County. Provided key components such as analysis, options, and feasibility which would secure greater local control. Researching legal and regulatory requirements and funding impacts.

Strategic Planning continued to the next Regular Meeting for further discussion and action

**Brief Reports**

This section is set aside for brief reports or presentation from listed agencies. Speakers are requested to keep their comments brief. Any speaker wishing to provide a more detailed discussion should request the discussion be agendaized at a future meeting.

- **OCCOG Technical Advisory Committee**

Nate Farnsworth, Technical Advisory Committee Chair, announced that the TAC continues to be focused on the REAP Grant.

- **Southern California Association of Governments**

Jonathan Hughes, Regional Affairs Officer, SCAG, announced four separate asks to the governor and state legislature for the housing element and flexibility, an extension of six months. Discussions are ongoing. Good amount of broad band funding in the state budget administered through SCAG.

- **South Coast Air Quality Management District**

Carlos Rodriguez, OCCOG Director; Debra Ashby, Senior Public Information Specialist SCAQMD; Link to May/June/July edition of SCAQMD Advisor Newsletter:

<http://www.aqmd.gov/home/research/publications/advisor-archive/current-edition>



## MINUTES

Thursday, June 24, 2021 | 10:30 a.m.

Debra Ashby gave an update on the board being dark in August. Encouraged board members to download the SCAQMD app.

- **Executive Director Report**

Marnie O'Brien Primmer, Executive Director

OCCOG has been working on a draft letter encouraging members the extension. SCAG has pushed back the need for OCCOG to notify if we will take the sub delegation. Currently reviewing at the staff level on the Agenda for August 2021. The General Assembly is taking place for November 17, 2021. It was recommended to the board if they know of any sponsors to send to the Executive Director.

- **Board Member Reports**

No Reports

- **Member Agency Reports**

No Reports

- **Staff Member Reports**

No Reports

### Future Agenda Items

#### Adjournment of Regular Meeting

The next OCCOG Regular Meeting will be on August 26, 2021, at a place to be determined, pending state and local public health orders in force at the time of the meeting.



## AGENDA ITEM #2

## OCCOG June 2021 Financial Report

### SUMMARY

OCCOG financial information is provided for Board review.

As of June 30, 2021, OCCOG had combined cash and investments of \$454,998.55 consisting of the following: a bank balance of \$83,510.82 at Citizens Business Bank outstanding checks in the amount of \$36,052.03 and an investment balance at the State Local Agency Investment Fund of \$407,539.76.

### STAFF RECOMMENDATION

Approve financial report.

### ATTACHMENTS

- A. OCCOG Fiscal Year 2020-21 Cash and Investments
- B. Citizens Business Bank Statement as of June 30, 2021
- C. State Local Agency Investment Fund (LAIF) Monthly Statement for June 30, 2021
- E. LAIF Performance Report - Period Ending May, 2021, Pooled Money Investment Account (PMIA) Average Monthly Effective Yields – March 2021 – April 2021 – May 2021 and PMIA Portfolio Composition at 5/31/21.
- F. OCCOG Fiscal Year 2020-21 Cash Receipts/Disbursements Report

### STAFF CONTACT

John Hanson, CPA  
OCCOG Treasure  
949-929-0073  
jhoccog@gmail.com

**Orange County Council of Governments  
Cash and Investments  
Fiscal Year 2020-21**

Date	Check #	Description	Amount	General Ledger Balance	Bank Balances and Reconciliation
<b>July</b>					
		Balance Forward		338,479.65	
7/2/2020	1551	Eileen White	(4,455.00)	334,024.65	
7/2/2020	1552	Connected Consulting	(10,802.99)	323,221.66	
7/2/2020	2047	Wendy J Strack Consulting	(2,500.00)	320,721.66	Bank of the West 29,548.45
7/2/2020	2048	Kathryn Morrison	(1,300.00)	319,421.66	Citizens Business Bank 181,238.76
7/2/2020	2049	John Hanson	(694.71)	318,726.95	O/S Checks (21,504.44)
7/2/2020	2050	Aleshire & Wynder, LLP	(2,340.00)	316,386.95	State LAIF 256,195.97
7/2/2020	2051	Communications Lab	(1,250.00)	315,136.95	<u>\$445,478.74</u>
7/14/2020	2052	Lisa Telles Communications	(1,000.00)	314,136.95	
7/14/2020	2053	City of Placentia	(157.00)	313,979.95	
7/20/2020		Bank of the West	(52.12)	313,927.83	
7/22/2020		Citizens Business Bank	(41.95)	313,885.88	
7/22/2020		City of Stanton	5,833.09	319,718.97	
7/22/2020		City of Los Alamitos	3,926.48	323,645.45	
7/22/2020		City of Newport Beach	11,069.90	334,715.35	
7/22/2020		City of Fountain Valley	8,997.51	343,712.86	
7/22/2020		City of Villa Park	3,524.43	347,237.29	
7/22/2020		Orange County Sanitation District	7,500.00	354,737.29	
7/22/2020		City of Laguna Woods	4,250.55	358,987.84	
7/29/2020		City of Rancho Santa Margarita	6,506.47	365,494.31	
7/29/2020		City of La Palma	4,198.51	369,692.82	
7/29/2020		City of Lake Forest	8,995.82	378,688.64	
7/29/2020		City of Laguna Niguel	9,651.62	388,340.26	
7/29/2020		City of Cypress	2,179.01	390,519.27	
7/29/2020		City of Cypress	4,360.66	394,879.93	
7/29/2020		City of Laguna Beach	4,673.31	399,553.24	
7/29/2020		City of Alsio Viejo	6,593.18	406,146.42	
7/29/2020		City of Costa Mesa	13,079.65	419,226.07	
7/29/2020		City of San Clemente	9,600.68	428,826.75	
7/29/2020		City of Buena Park	8,807.79	437,634.54	
7/29/2020		City of La Habra	7,516.82	445,151.36	
7/29/2020		City of Dana Point	5,422.04	450,573.40	
7/29/2020		City of Placentia	6,693.67	457,267.07	
7/29/2020		City of Tustin	8,695.79	465,962.86	
7/29/2020		Local Agency Investment Fund	1,020.88	466,983.74	
7/31/2020	2054	CALCOG	(2,100.00)	464,883.74	
7/31/2020	2055	John Hanson	(819.45)	464,064.29	
7/31/2020	2056	Aleshire & Wynder, LLP	(1,782.00)	462,282.29	
7/31/2020	2057	Wendy J Strack Consulting	(2,500.00)	459,782.29	
7/31/2020	2058	Connected Consulting	(10,802.99)	448,979.30	
7/31/2020	2059	VOID	-	448,979.30	
7/31/2020	2060	Lisa Telles Communications	(1,000.00)	447,979.30	
7/31/2020	2061	Kathryn Morrison	(1,250.00)	446,729.30	
7/31/2020	2062	Communications Lab	(1,250.00)	445,479.30	

**Orange County Council of Governments  
Cash and Investments  
Fiscal Year 2020-21**

Date	Check #	Description	Amount	General Ledger Balance	Bank Balances and Reconciliation
<b>August</b>					Bank of the West 29,548.45
					Citizens Business Bank 305,784.65
8/12/2020		City of Santa Ana	31,346.03	476,825.33	O/S Checks (27,678.18)
8/12/2020		City of Fullerton	12,956.81	489,782.14	State LAIF 256,195.97
8/12/2020		City of San Juan Capistrano	5,641.88	495,424.02	<u>\$563,850.89</u>
8/12/2020		City of Irvine	22,648.88	518,072.90	
8/24/2020		City of Anaheim	32,889.68	550,962.58	
8/24/2020		City of Huntington Beach	17,074.85	568,037.43	
8/24/2020		City of Seal Beach	4,856.91	572,894.34	
8/24/2020		Citizens Business Bank	(35.13)	572,859.21	
8/31/2020		City of Yorba Linda	9,882.68	582,741.89	
8/31/2020		City of Brea	8,287.18	591,029.07	
8/31/2020		ISDOC	500.00	591,529.07	
8/31/2020	2063	Aleshire & Wynder	(684.00)	590,845.07	
8/31/2020	2064	John Hanson	(909.91)	589,935.16	
8/31/2020	2065	Communications Lab	(2,500.00)	587,435.16	
8/31/2020	2066	Wendy J Strack Consulting	(2,500.00)	584,935.16	
8/31/2020	2067	Kathryn Morrison	(1,750.00)	583,185.16	
8/31/2020	2068	Lisa Telles Communications	(1,000.00)	582,185.16	
8/31/2020	2069	AJ Design	(4,500.00)	577,685.16	
8/31/2020	1553	Connected Consulting	(10,834.27)	566,850.89	
8/31/2020	1554	Elaine White	(3,000.00)	563,850.89	
<b>September</b>					Bank of the West 15,714.18
					Citizens Business Bank 333,670.66
9/8/2020		City of Mission Viejo	11,658.11	575,509.00	O/S Checks (31,045.43)
9/8/2020		City of San Juan Capistrano	2,000.00	577,509.00	State LAIF 256,195.97
9/8/2020		City of Garden Grove	15,239.62	592,748.62	<u>\$574,535.38</u>
9/22/2020		City of Orange	12,832.19	605,580.81	
9/30/2020	2070	Wavelength Automation	(1,428.00)	604,152.81	
9/30/2020	2071	Eide Bailly	(6,000.00)	598,152.81	
9/30/2020	2072	Eileen White	(1,500.00)	596,652.81	
9/30/2020	2073	Lisa Telles Communications	(1,000.00)	595,652.81	
9/30/2020	2074	Kathryn Morrison	(1,714.94)	593,937.87	
9/30/2020	2075	Wendy J Strack Consulting	(2,500.00)	591,437.87	
9/30/2020	2076	John Hanson	(1,035.21)	590,402.66	
9/30/2020	2077	Aleshire & Wynder	(2,934.00)	587,468.66	
9/30/2020	1555	Connected Consulting	(10,433.28)	577,035.38	
9/30/2020	1556	Communications Lab	(2,500.00)	574,535.38	



**Orange County Council of Governments  
Cash and Investments  
Fiscal Year 2020-21**

Date	Check #	Description	Amount	General Ledger Balance	Bank Balances and Reconciliation
<b>October</b>					
10/5/2020		OCTA	9,000.00	583,535.38	Bank of the West 2,591.13
10/5/2020		Orange County Water District	50,000.00	633,535.38	Citizens Business Bank 440,588.68
10/15/2020		Local Agency Investment Fund Interest	544.00	634,079.38	O/S Checks (77,305.55)
10/22/2020		Municipal Water District of OC	50,000.00	684,079.38	State LAIF 256,739.97
10/22/2020		SoCal Gas	5,000.00	689,079.38	<u>\$622,614.23</u>
10/29/2020		City of Westminster	9,530.17	698,609.55	
10/31/2020	2078	Kathryn Morrison	(1,759.96)	696,849.59	
10/31/2020	2079	Wendy J Strack Consulting	(2,500.00)	694,349.59	
10/31/2020	2080	John Hanson	(1,036.70)	693,312.89	
10/31/2020	2081	Aleshire & Wynder, LLP	(1,620.00)	691,692.89	
10/31/2020	2082	Communications Lab	(2,500.00)	689,192.89	
10/31/2020	2083	CSUFAS	(26,550.16)	662,642.73	
10/31/2020	2084	CSUFAS	(26,550.16)	636,092.57	
10/31/2020	2085	Lisa Telles Communications	(1,000.00)	635,092.57	
10/31/2020	2086	Connected Consulting	(10,788.57)	624,304.00	
10/31/2020	2087	Eileen White	(1,500.00)	622,804.00	
10/31/2020		Bank of the West	(189.77)	622,614.23	
<b>November</b>					
11/5/2020		City of Laguna Hills	3,768.79	626,383.02	Bank of the West 2,591.13
11/5/2020		TCA	9,000.00	635,383.02	Citizens Business Bank 382,551.92
11/16/2020		City of Garden Grove	2,000.00	637,383.02	O/S Checks (24,899.07)
11/27/2020		City of Tuston	2,000.00	639,383.02	State LAIF 256,739.97
11/30/2020	2088	John Hanson	(941.30)	638,441.72	<u>\$616,983.95</u>
11/30/2020	2089	Aleshire & Wynder	(1,008.50)	637,433.22	
11/30/2020	2090	Communications Lab	(2,500.00)	634,933.22	
11/30/2020	2091	Kathryn Morrison	(1,589.99)	633,343.23	
11/30/2020	2092	Lisa Telles Communications	(1,000.00)	632,343.23	
11/30/2020	2093	Eileen White	(1,500.00)	630,843.23	
11/30/2020	2094	Wendy J Strack Consulting	(2,500.00)	628,343.23	
11/30/2020	2095		(10,783.28)	617,559.95	
11/30/2020	2096	Aleshire & Wynder	(576.00)	616,983.95	
<b>December</b>					
12/11/2020		California Association of Cities	500.00	617,483.95	Bank of the West 2,591.13
12/29/2020		LSA	1,000.00	618,483.95	Citizens Business Bank 368,152.85
12/29/2020		SCAQMD	7,500.00	625,983.95	O/S Checks (10,314.99)
12/31/2020	2097	Communications Lab	(2,500.00)	623,483.95	State LAIF 256,739.97
12/31/2020	2099	Wendy J Strack Consulting	(2,500.00)	620,983.95	<u>\$617,168.96</u>
12/31/2020	2150	Lisa Telles Communications	(1,000.00)	619,983.95	
12/31/2020	2152	Eileen White	(1,500.00)	618,483.95	

**Orange County Council of Governments  
Cash and Investments  
Fiscal Year 2020-21**

Date	Check #	Description	Amount	General Ledger Balance	Bank Balances and Reconciliation
12/31/2020	2153	VOID	-	618,483.95	
12/31/2020	2155	Kathryn Morrison	(1,314.99)	617,168.96	
<hr/>					
<b>January</b>					
1/1/2021	2098	John Hanson	(496.65)	616,672.31	Bank of the West \$2,347.20
1/1/2021	2154	Connected Consulting	(10,783.28)	605,889.03	Citizens Business Bank \$263,682.93
1/4/2021	2151	Eide Bailly	(1,650.00)	604,239.03	O/S Checks (25,617.61)
1/29/2021		Orange County Fire Authority	62,275.00	666,514.03	State LAIF 407,145.91
1/29/2021		TCA	1,500.00	668,014.03	<u>\$647,558.43</u>
1/29/2021		City of Lake Forest	2,000.00	670,014.03	
1/31/2021	2156	Lisa Telles Communications	(1,000.00)	669,014.03	
1/31/2021	2157	John Hanson	(826.67)	668,187.36	
1/31/2021	2158	Kathryn Morrison	(2,427.80)	665,759.56	
1/31/2021	2159	Wendy J Strack Consulting	(2,500.00)	663,259.56	
1/31/2021	2160	Communications Lab	(2,500.00)	660,759.56	
1/31/2021		LAIF	405.94	661,165.50	
1/31/2021	2161	VOID	-	661,165.50	
1/31/2021	2162	Aleshire & Wynder	(1,080.00)	660,085.50	
1/31/2021	2163	Elaine White	(1,500.00)	658,585.50	
1/31/2021	2164	VOID	-	660,085.50	
1/31/2021		Bank Fees	(243.93)	658,341.57	
1/31/2021	2165	Connected Consulting	(10,783.14)	647,558.43	
<hr/>					
<b>February</b>					
02/28/2021	2166	CSUF ASC	(26,050.16)	621,508.27	Bank of West \$0.00
02/28/2021	2167	John Hanson	(772.63)	620,735.64	Citizens Business Bank \$247,172.52
02/28/2021	2168	Praetorian Digital	(1,500.00)	619,235.64	O/S Checks (60,237.95)
02/28/2021	2169	Lisa Telles Communications	(1,000.00)	618,235.64	State LAIF 407,145.91
02/28/2021	2170	Wendy J Strack Consulting	(2,500.00)	615,735.64	<u>\$594,080.48</u>
02/28/2021	2171	VOID	0.00	615,735.64	
02/28/2021	2172	Alissa Pier	(597.46)	615,138.18	
02/28/2021	2173	Aleshire & Wynder, LLP	(3,870.00)	611,268.18	
02/28/2021	2174	Communications Lab	(2,500.00)	608,768.18	
02/28/2021	2175	VOID	0.00	608,768.18	
02/28/2021	2176	Kathryn Morrison	(2,164.56)	606,603.62	
02/28/2021	2177	Connected Consulting	(10,783.14)	595,820.48	
02/28/2021	2178	Elaine White	(1,500.00)	594,320.48	
02/28/2021		Bank of the West	(240.00)	594,080.48	

**Orange County Council of Governments  
Cash and Investments  
Fiscal Year 2020-21**



Date	Check #	Description	Amount	General Ledger Balance	Bank Balances and Reconciliation
<b>March</b>					
					Citizens Business Bank 188,934.57
3/22/2021		Los Alamitos OCDAP	2,000.00	596,080.48	O/S Checks (25,591.79)
3/31/2021	2179	Kathryn Morrison	(2,350.92)	593,729.56	State LAIF 407,145.91
3/31/2021	2180	Lisa Telles Communications	(1,000.00)	592,729.56	<u>570,488.69</u>
3/31/2021	2181	Communications Lab	(2,500.00)	590,229.56	
3/31/2021	2182	John Hanson	(821.73)	589,407.83	
3/31/2021	2183	CSUF ASC	(500.00)	588,907.83	
3/31/2021	2184	Aleshire & Wynder, LLP	(3,636.00)	585,271.83	
3/31/2021	2185	Wendy J Strack Consulting	(2,500.00)	582,771.83	
3/31/2021	2186	Eileen White	(1,500.00)	581,271.83	
3/31/2021	2187	Connected Consulting	(10,783.14)	570,488.69	
<b>April</b>					
					Citizens Business Bank 174,842.78
04/08/2021		City of Irvine	5,000.00	575,488.69	O/S Checks (57,773.79)
04/15/2021		Southern California Edison	5,000.00	580,488.69	State LAIF 407,539.76
04/15/2021		Local Agency Investment Fund	393.85	580,882.54	<u>524,608.75</u>
04/30/2021	2188	Aleshire & Wynder, LLP	(5,007.00)	575,875.54	
04/30/2021	2189	Communications Lab	(2,500.00)	573,375.54	
04/30/2021	2190	CSU Fullerton Auxillary Services	(26,550.16)	546,825.38	
04/30/2021	2191	John Hanson	(857.48)	545,967.90	
04/30/2021	2192	AJ Design	(1,085.00)	544,882.90	
04/30/2021	2193	Eileen White	(1,500.00)	543,382.90	
04/30/2021	2194	VOID	-	543,382.90	
04/30/2021	2195	VOID	-	543,382.90	
04/30/2021	2196	Wendy J Strack Consulting	(2,500.00)	540,882.90	
04/30/2021	2197	Kathryn Morrison	(1,991.01)	538,891.89	
04/30/2021	2198	Lisa Telles Communications	(1,000.00)	537,891.89	
04/30/2021	2199	Connected Consulting	(10,783.14)	527,108.75	
04/30/2021	2100	Kris Murray	(2,500.00)	524,608.75	
<b>May</b>					
					Citizens Business Bank 120,568.55
5/21/2021		Neighbors Housing Services	500.00	525,108.75	O/S Checks (41,549.73)
5/31/2021	2101	Communications Lab	(2,500.00)	522,608.75	State LAIF 407,539.76
5/31/2021	2102	California JPIA	(11,000.00)	511,608.75	<u>486,558.58</u>
5/31/2021	2103	Aleshire & Wynder, LLP	(6,151.80)	505,456.95	
5/31/2021	2104	John Hanson	(978.34)	504,478.61	
5/31/2021	2105	Eileen White	(1,500.00)	502,978.61	
5/31/2021	2106	Kathryn Morrison	(2,074.99)	500,903.62	
5/31/2021	2107	Wendy J Strack Consulting	(2,500.00)	498,403.62	
5/31/2021	2108	Lisa Telles Communications	(1,000.00)	497,403.62	
5/31/2021	2109	Connected Consulting	(10,844.60)	486,559.02	
5/31/2021		Citizens Business Bank	(0.44)	486,558.58	

**Orange County Council of Governments  
Cash and Investments  
Fiscal Year 2020-21**

Date	Check #	Description	Amount	General Ledger Balance	Bank Balances and Reconciliation
<b>June</b>					
6/22/2021		Citizens Business Bank	(8.00)	486,550.58	Citizens Business Bank 83,510.82
6/30/2021	2110	Communications Lab	(2,500.00)	484,050.58	O/S Checks (36,052.03)
6/30/2021	2111	Aleshire & Wynder, LLP	(10,152.00)	473,898.58	State LAIF 407,539.76
6/30/2021	2112	John Hanson	(584.15)	473,314.43	<u>454,998.55</u>
6/30/2021	2113	Lisa Telles Communications	(1,000.00)	472,314.43	
6/30/2021	2114	Wendy J Strack Consulting	(2,500.00)	469,814.43	
6/30/2021	2115	Eileen White	(1,500.00)	468,314.43	
6/30/2021	2116	Connected Consulting	(10,842.57)	457,471.86	
6/30/2021	2115	Kathryn Morrison	(2,473.31)	454,998.55	

ORANGE COUNTY COUNCIL OF GOVERNMENTS  
3972 BARRANCA PKWY STE J127  
IRVINE CA 92606-1204

### Managing Your Accounts

	Phone Number	888.222.5432
	Website	cbbank.com
	Email	customersupport@cbbank.com

### Summary of Accounts

Account Type	Account Number	Ending Balance
ANALYZED BUSINESS PLAN GOVERNMENT SRVCS	591004948	\$83,510.82

## ANALYZED BUSINESS PLAN GOVERNMENT SRVCS-591004948

### Account Summary

Date	Description	Amount
05/29/2021	Beginning Balance	\$120,568.55
	0 Credit(s) This Period	\$0.00
	9 Debit(s) This Period	\$37,057.73
06/30/2021	Ending Balance	\$83,510.82

### Other Debits

Date	Description	Amount
06/22/2021	Account Analysis Fees	\$8.00
		1 item(s) totaling \$8.00

### Checks Cleared

Check Nbr	Date	Amount	Check Nbr	Date	Amount	Check Nbr	Date	Amount
2101	06/17/2021	\$2,500.00	2104	06/04/2021	\$978.34	2108	06/08/2021	\$1,000.00
2102	06/11/2021	\$11,000.00	2106*	06/07/2021	\$2,074.99	2109	06/08/2021	\$10,844.60
2103	06/09/2021	\$6,151.80	2107	06/15/2021	\$2,500.00			

\* Indicates skipped check number

8 item(s) totaling \$37,049.73

### Daily Balances

Date	Amount	Date	Amount	Date	Amount
06/04/2021	\$119,590.21	06/09/2021	\$99,518.82	06/17/2021	\$83,518.82
06/07/2021	\$117,515.22	06/11/2021	\$88,518.82	06/22/2021	\$83,510.82
06/08/2021	\$105,670.62	06/15/2021	\$86,018.82		

OUTSTANDING CHECKS		INSTRUCTIONS
No.	Amount	<p>PLEASE EXAMINE THIS STATEMENT AT ONCE AND IMMEDIATELY NOTIFY THE BANK OF ANY ERRORS.</p> <p>ALL ITEMS CREDITED ARE SUBJECT TO FINAL PAYMENT.</p> <ol style="list-style-type: none"> <li>Compare each paid check with your check stub or register and mark as paid.</li> <li>Bank balance shown on front of your statement..... _____</li> <li>Compare any deposits shown on statement, including bank originated credits, with those entered in your check register. Add any not shown on statement..... _____</li> <li>Subtotal..... _____</li> <li>Subtract total of outstanding checks..... _____</li> <li>Account Balance..... _____</li> <li>Your check book balance..... _____</li> <li>Subtract any bank charges including monthly service charge or transfers you have authorized and have been deducted on this statement..... _____</li> <li>Adjusted check book balance..... _____</li> </ol> <p><i>*Denotes a point at which one or more check serial numbers are unaccounted for this statement period. It may indicate outstanding checks or checks shown on previous statements.</i></p>
TOTAL		

**STATEMENTS AND IMAGES**

Your account statement will include the following information with respect to each check paid against your account during the statement cycle: (1) the check number (2) the amount of the check; and (3) the date of the payment. Copies of checks can be requested by calling customer service at (888) 222-5432. Please refer to our Bank Product and Service Information for applicable fees under Research Requests.

**THE FOLLOWING NOTICE CONCERNING ELECTRONIC TRANSFER APPLIES IF YOUR ACCOUNT IS MAINTAINED FOR PERSONAL, FAMILY OR HOUSEHOLD PURPOSES.**

**IN CASE OF ERRORS OR QUESTIONS ABOUT YOUR ELECTRONIC TRANSFERS CONTACT US AT:**

Telephone: (888) 222-5432  
or write us at:  
Citizens Business Bank P O Box 51000, Ontario, CA 91761

Contact us as soon as you can if you think your statement or receipt is wrong or if you need more information about a transfer on the statement or a receipt. We must hear from you no later than 60 days after we sent you the FIRST statement on which the error or problem appeared. If you have a question concerning your statement, please be prepared to:

- Provide your name and account number (if any).
- Provide the dollar amount of the suspected error.
- Describe the error or the transfer you are unsure about and clearly explain why you believe it is an error or why you need more information.

We will investigate your complaint and will correct any error promptly. If we take more than 10 business days to do this, we will credit your account for the amount you think is in error, so that you will have the use of the money during the time it takes us to complete our investigation

# California State Treasurer *Fiona Ma, CPA*



Local Agency Investment Fund  
P.O. Box 942809  
Sacramento, CA 94209-0001  
(916) 653-3001

July 04, 2021

[LAIF Home](#)  
[PMIA Average Monthly Yields](#)

## ORANGE COUNTY COUNCIL OF GOVERNMENTS

TREASURER  
3972 BARRANCA PKWY  
SUITE J127  
IRVINE , CA 92606

[Tran Type Definitions](#)

//

**Account Number:** 40-30-020

June 2021 Statement

### Account Summary

Total Deposit:	0.00	Beginning Balance:	407,539.76
Total Withdrawal:	0.00	Ending Balance:	407,539.76



# PMIA/LAIF Performance Report as of 06/11/21



## PMIA Average Monthly Effective Yields<sup>(1)</sup>

May	0.315
Apr	0.339
Mar	0.357

## Quarterly Performance Quarter Ended 03/31/21

LAIF Apportionment Rate <sup>(2)</sup> :	0.44
LAIF Earnings Ratio <sup>(2)</sup> :	0.00001214175683392
LAIF Fair Value Factor <sup>(1)</sup> :	1.001269853
PMIA Daily <sup>(1)</sup> :	0.35%
PMIA Quarter to Date <sup>(1)</sup> :	0.41%
PMIA Average Life <sup>(1)</sup> :	220

## Pooled Money Investment Account Monthly Portfolio Composition <sup>(1)</sup> 05/31/21 \$153.4 billion

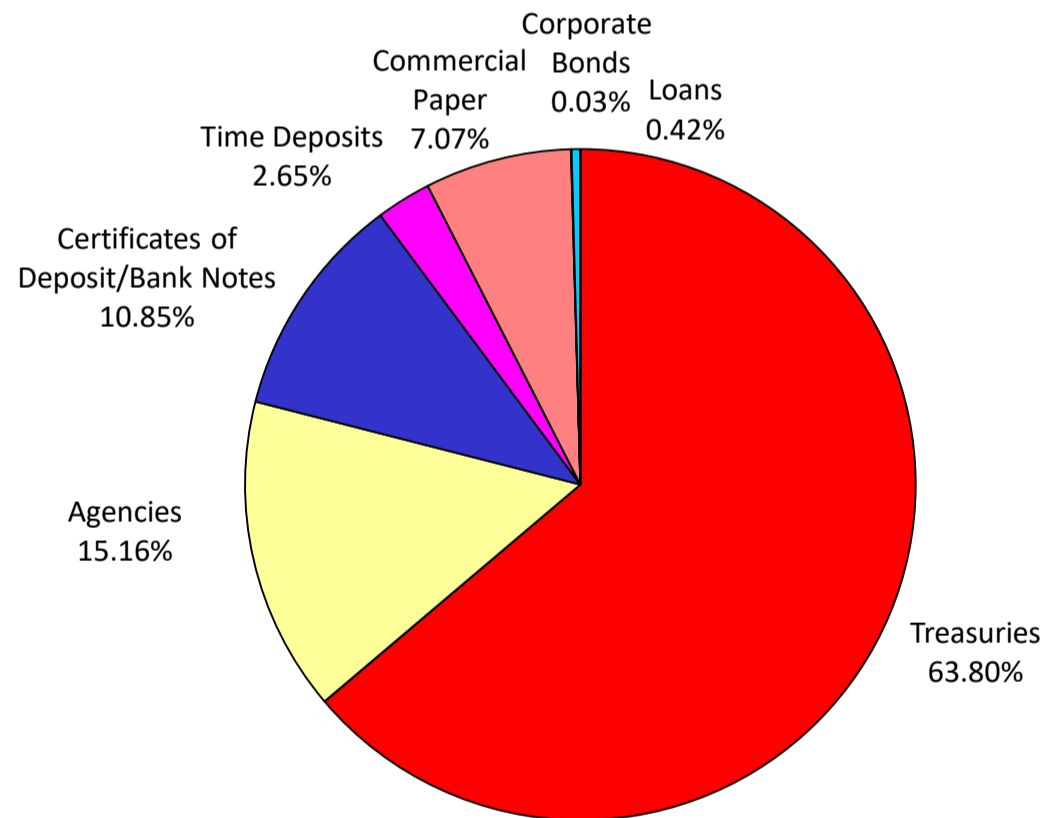

Chart does not include 0.01% of mortgages. Percentages may not total 100% due to rounding.

Daily rates are now available here. [View PMIA Daily Rates](#)

Notes: The apportionment rate includes interest earned on the CalPERS Supplemental Pension Payment pursuant to Government Code 20825 (c)(1) and interest earned on the Wildfire Fund loan pursuant to Public Utility Code 3288 (a).

Source:

<sup>(1)</sup> State of California, Office of the Treasurer

<sup>(2)</sup> State of California, Office of the Controller



**Orange County Council of Governments  
Cash Receipts/Disbursements Report  
For the Quarter ending June 30, 2021**

**Cash Receipts**

<b>Date</b>	<b>Payer</b>	<b>Description</b>	<b>Amount</b>
04/08/2021	City of Irvine	Cycle 1 Data Payment	5,000.00
04/15/2021	Southern California Edison	General Assembly Sponsorship	5,000.00
04/15/2021	Local Agency Investment Fund	Quarterly Interest	393.85
5/21/2021	Neighbors Housing Services	General Assembly Sponsorship	500.00
			10,893.85

**Cash Disbursements**

<b>Date</b>	<b>Check #</b>	<b>Payee</b>	<b>Description</b>	<b>Amount</b>
04/30/2021	2188	Aleshire & Wynder, LLP	March Legal	(5,007.00)
04/30/2021	2189	Communications Lab	Social Media/Web Site March 2021	(2,500.00)
	2190	CSU Fullerton Auxillary Services		(26,550.16)
04/30/2021			4th Quarter CDR	
04/30/2021	2191	John Hanson	March/April Treasurer Services	(857.48)
04/30/2021	2192	AJ Design	OCCOG Housing Videos	(1,085.00)
04/30/2021	2193	Eileen White	April Clerk of the Board	(1,500.00)
04/30/2021	2194	VOID		-
04/30/2021	2195	VOID		-
04/30/2021	2196	Wendy J Strack Consulting	Strategy and Advocacy Services April 2021	(2,500.00)
04/30/2021	2197	Kathryn Morrison	Administrative Assistant April 2021	(1,991.01)
04/30/2021	2198	Lisa Telles Communications	General Assembly Special Events April 2021	(1,000.00)
04/30/2021	2199	Connected Consulting	April Executive Director	(10,783.14)
04/30/2021	2100	Kris Murray (KLM Inc)	Government Relations	(2,500.00)
5/31/2021	2101	Communications Lab	Social Media/Web Site April 2021	(2,500.00)
5/31/2021	2102	California JPIA	Fiscal Year 2021/22 General Liability	(11,000.00)
5/31/2021	2103	Aleshire & Wynder, LLP	April Legal	(6,151.80)
5/31/2021	2104	John Hanson	April/May Treasurer Services	(978.34)
5/31/2021	2105	Eileen White	May Clerk of the Board	(1,500.00)
5/31/2021	2106	Kathryn Morrison	Administrative Assistant May 2021	(2,074.99)
5/31/2021	2107	Wendy J Strack Consulting	Strategy and Advocacy Services May 2021	(2,500.00)
5/31/2021	2108	Lisa Telles Communications	General Assembly Special Events May 2021	(1,000.00)
5/31/2021	2109	Connected Consulting	May Executive Director	(10,844.60)
5/31/2021		Citizens Business Bank	Banking fees	(0.44)
6/22/2021		Account Analysis Fee	Banking fees	(8.00)
6/30/2021	2110	Communications Lab	Social Media/Web Site May 2021	(2,500.00)
6/30/2021	2111	Aleshire & Wynder, LLP	May Legal	(10,152.00)
6/30/2021	2112	John Hanson	May/June Treasurer Services	(584.15)
6/30/2021	2113	Lisa Telles Communications	General Assembly Special Events June 2021	(1,000.00)
6/30/2021	2114	Wendy J Strack Consulting	Strategy and Advocacy Services June 2021	(2,500.00)
6/30/2021	2115	Eileen White	June Clerk of the Board	(1,500.00)
6/30/2021	2116	Connected Consulting	June Executive Director	(10,842.57)
6/30/2021	2115	Kathryn Morrison	Administrative Assistant June 2021	(2,473.31)
				(126,383.99)



## AGENDA ITEM #2

## OCCOG July 2021 Financial Report

### SUMMARY

OCCOG financial information is provided for Board review.

As of July 31, 2021, OCCOG had combined cash and investments of \$499,484.34. consisting of the following: a bank balance of \$145,698.92 at Citizens Business Bank outstanding checks in the amount of \$54,087.09 and an investment balance at the State Local Agency Investment Fund of \$407,872.51.

### STAFF RECOMMENDATION

Approve financial report.

### ATTACHMENTS

- A. OCCOG Fiscal Year 2021-22 Cash and Investments
- B. Citizens Business Bank Statement as of July 31, 2021
- C. State Local Agency Investment Fund (LAIF) Monthly Statement for July 31, 2021
- E. LAIF Performance Report - Period Ending June 30, 2021, Pooled Money Investment Account (PMIA) Average Monthly Effective Yields – May 2021 – June 2021 – July 2021 and PMIA Portfolio Composition at 6/30/21.
- F. OCCOG Fiscal Year 2021-22 Cash Receipts/Disbursements Report

### STAFF CONTACT



John Hanson, CPA  
OCCOG Treasure  
949-929-0073  
jhoccog@gmail.com

**Orange County Council of Governments  
Cash and Investments  
Fiscal Year 2021-22**

Date	Check #	Description	Amount	General Ledger Balance	Bank Balances and Reconciliation
<b>July</b>					
		Balance Forward		454,998.55	
7/7/2021		Citizens Business Bank	(140.34)	454,858.21	Citizens Business Bank 145,698.92
7/15/2021		Local Agency Investment Fund	332.75	455,190.96	O/S Checks (54,087.09)
7/15/2021	2118	Communications Lab	(2,500.00)	452,690.96	State LAIF 407,872.51
7/19/2021		City of Seal Beach	4,904.68	457,595.64	\$499,484.34
7/19/2021		City of San Juan Capistrano	5,712.70	463,308.34	
7/19/2021		City of Los Alamitos	3,986.60	467,294.94	
7/19/2021		City of Laguna Woods	4,306.59	471,601.53	
7/19/2021		City of Villa Park	3,575.47	475,177.00	
7/22/2021		City of Newport Beach	9,274.33	484,451.33	
7/22/2021		City of Placentia	6,806.29	491,257.62	
7/22/2021		SVA Architects	1,000.00	492,257.62	
7/23/2021		Citizens Business Bank	(20.42)	492,237.20	
7/27/2021		OCTA	9,000.00	501,237.20	
7/27/2021		City of Fountain Valley	7,075.20	508,312.40	
7/27/2021		City of Yorba Linda	7,992.43	516,304.83	
7/27/2021		City of La Habra	7,634.02	523,938.85	
7/27/2021		City of Rancho Santa Margarita	6,593.58	530,532.43	
7/27/2021		City of La Palma	4,264.33	534,796.76	
7/27/2021		City of Laguna Niguel	7,801.91	542,598.67	
7/27/2021		City of Buena Park	8,972.76	551,571.43	
7/27/2021		City of Buena Park	2,000.00	553,571.43	
7/31/2021	2119	Aleshire & Wynder, LLP	(4,376.00)	549,195.43	
7/31/2021	2120	CSU FAS	(27,594.66)	521,600.77	
7/31/2021	2121	VOID	-	521,600.77	
7/31/2021	2122	CALCOG	(2,369.00)	519,231.77	
7/31/2021	2123	Lisa Telles Communications	(2,500.00)	516,731.77	
7/31/2021	2124	John Hanson	(980.20)	515,751.57	
7/31/2021	2125	Kathryn Morrison	(2,659.99)	513,091.58	
7/31/2021	2126	Connected Consulting	(11,107.24)	501,984.34	
7/31/2021	2127	WJS Consulting	(2,500.00)	499,484.34	

ORANGE COUNTY COUNCIL OF GOVERNMENTS  
3972 BARRANCA PKWY STE J127  
IRVINE CA 92606-1204

### Managing Your Accounts

	Phone Number	888.222.5432
	Website	cbbank.com
	Email	customersupport@cbbank.com

### Summary of Accounts

Account Type	Account Number	Ending Balance
ANALYZED BUSINESS PLAN GOVERNMENT SRVCS	591004948	\$145,698.92

## ANALYZED BUSINESS PLAN GOVERNMENT SRVCS-591004948

### Account Summary

Date	Description	Amount
07/01/2021	Beginning Balance	\$83,510.82
	3 Credit(s) This Period	\$100,900.89
	14 Debit(s) This Period	\$38,712.79
07/30/2021	Ending Balance	\$145,698.92

### Deposits

Date	Description	Amount
07/19/2021	DEPOSIT	\$22,486.04
07/22/2021	DEPOSIT	\$17,080.62
07/27/2021	DEPOSIT	\$61,334.23
		3 item(s) totaling \$100,900.89

### Electronic Debits

Date	Description	Amount
07/07/2021	HARLAND CLARKE CHK ORDER 1T7U06070327600	\$140.34
		1 item(s) totaling \$140.34

### Other Debits

Date	Description	Amount
07/23/2021	Account Analysis Fees	\$20.42
		1 item(s) totaling \$20.42

### Checks Cleared

Check Nbr	Date	Amount	Check Nbr	Date	Amount	Check Nbr	Date	Amount
2105	07/15/2021	\$1,500.00	2113	07/12/2021	\$1,000.00	2117	07/08/2021	\$2,473.31
2110*	07/07/2021	\$2,500.00	2114	07/22/2021	\$2,500.00	2118	07/20/2021	\$2,500.00
2111	07/07/2021	\$10,152.00	2115	07/15/2021	\$1,500.00	2186*	07/15/2021	\$1,500.00
2112	07/07/2021	\$584.15	2116	07/14/2021	\$10,842.57	2193*	07/15/2021	\$1,500.00

\* Indicates skipped check number

12 item(s) totaling \$38,552.03

OUTSTANDING CHECKS		INSTRUCTIONS
No.	Amount	<p style="text-align: center;"><b>PLEASE EXAMINE THIS STATEMENT AT ONCE AND IMMEDIATELY NOTIFY THE BANK OF ANY ERRORS.</b></p> <p style="text-align: center;"><b>ALL ITEMS CREDITED ARE SUBJECT TO FINAL PAYMENT.</b></p> <ol style="list-style-type: none"> <li>1. Compare each paid check with your check stub or register and mark as paid.</li> <li>2. Bank balance shown on front of your statement..... _____</li> <li>3. Compare any deposits shown on statement, including bank originated credits, with those entered in your check register. Add any not shown on statement..... _____</li> <li>4. Subtotal..... _____</li> <li>5. Subtract total of outstanding checks..... _____</li> <li>6. Account Balance..... _____</li> <li>7. Your check book balance..... _____</li> <li>8. Subtract any bank charges including monthly service charge or transfers you have authorized and have been deducted on this statement..... _____</li> <li>9. Adjusted check book balance..... _____</li> </ol> <p style="font-size: small; margin-top: 10px;"><i>*Denotes a point at which one or more check serial numbers are unaccounted for this statement period. It may indicate outstanding checks or checks shown on previous statements.</i></p>
<b>TOTAL</b>		

**STATEMENTS AND IMAGES**

Your account statement will include the following information with respect to each check paid against your account during the statement cycle: (1) the check number (2) the amount of the check; and (3) the date of the payment. Copies of checks can be requested by calling customer service at (888) 222-5432. Please refer to our Bank Product and Service Information for applicable fees under Research Requests.

**THE FOLLOWING NOTICE CONCERNING ELECTRONIC TRANSFER APPLIES IF YOUR ACCOUNT IS MAINTAINED FOR PERSONAL, FAMILY OR HOUSEHOLD PURPOSES.**

**IN CASE OF ERRORS OR QUESTIONS ABOUT YOUR ELECTRONIC TRANSFERS CONTACT US AT:**

**Telephone: (888) 222-5432**  
**or write us at:**  
**Citizens Business Bank P O Box 51000, Ontario, CA 91761**

Contact us as soon as you can if you think your statement or receipt is wrong or if you need more information about a transfer on the statement or a receipt. We must hear from you no later than 60 days after we sent you the FIRST statement on which the error or problem appeared. If you have a question concerning your statement, please be prepared to:

1. Provide your name and account number (if any).
2. Provide the dollar amount of the suspected error.
3. Describe the error or the transfer you are unsure about and clearly explain why you believe it is an error or why you need more information.

We will investigate your complaint and will correct any error promptly. If we take more than 10 business days to do this, we will credit your account for the amount you think is in error, so that you will have the use of the money during the time it takes us to complete our investigation

**ANALYZED BUSINESS PLAN GOVERNMENT SRVCS-591004948 (continued)****Daily Balances**

<u>Date</u>	<u>Amount</u>	<u>Date</u>	<u>Amount</u>	<u>Date</u>	<u>Amount</u>
07/07/2021	\$70,134.33	07/15/2021	\$49,818.45	07/23/2021	\$84,364.69
07/08/2021	\$67,661.02	07/19/2021	\$72,304.49	07/27/2021	\$145,698.92
07/12/2021	\$66,661.02	07/20/2021	\$69,804.49		
07/14/2021	\$55,818.45	07/22/2021	\$84,385.11		

THIS PAGE LEFT INTENTIONALLY BLANK

California State Treasurer  
**Fiona Ma, CPA**



Local Agency Investment Fund  
 P.O. Box 942809  
 Sacramento, CA 94209-0001  
 (916) 653-3001

August 02, 2021

[LAIF Home](#)  
[PMIA Average Monthly Yields](#)

ORANGE COUNTY COUNCIL OF GOVERNMENTS

TREASURER  
 3972 BARRANCA PKWY  
 SUITE J127  
 IRVINE , CA 92606

[Tran Type Definitions](#)

**Account Number:** 40-30-020

July 2021 Statement

Effective Date	Transaction Date	Tran Type	Confirm Number	Web Confirm Number	Authorized Caller	Amount
7/15/2021	7/14/2021	QRD	1679505	N/A	SYSTEM	332.75

**Account Summary**

Total Deposit:	332.75	Beginning Balance:	407,539.76
Total Withdrawal:	0.00	Ending Balance:	407,872.51





# PMIA/LAIF Performance Report as of 08/05/21



## PMIA Average Monthly Effective Yields<sup>(1)</sup>

Jul	0.221
Jun	0.262
May	0.315

## Quarterly Performance Quarter Ended 06/30/21

LAIF Apportionment Rate <sup>(2)</sup> :	0.33
LAIF Earnings Ratio <sup>(2)</sup> :	0.00000897371743018
LAIF Fair Value Factor <sup>(1)</sup> :	1.00008297
PMIA Daily <sup>(1)</sup> :	0.22%
PMIA Quarter to Date <sup>(1)</sup> :	0.30%
PMIA Average Life <sup>(1)</sup> :	291

## Pooled Money Investment Account Monthly Portfolio Composition <sup>(1)</sup> 06/30/21 \$193.3 billion

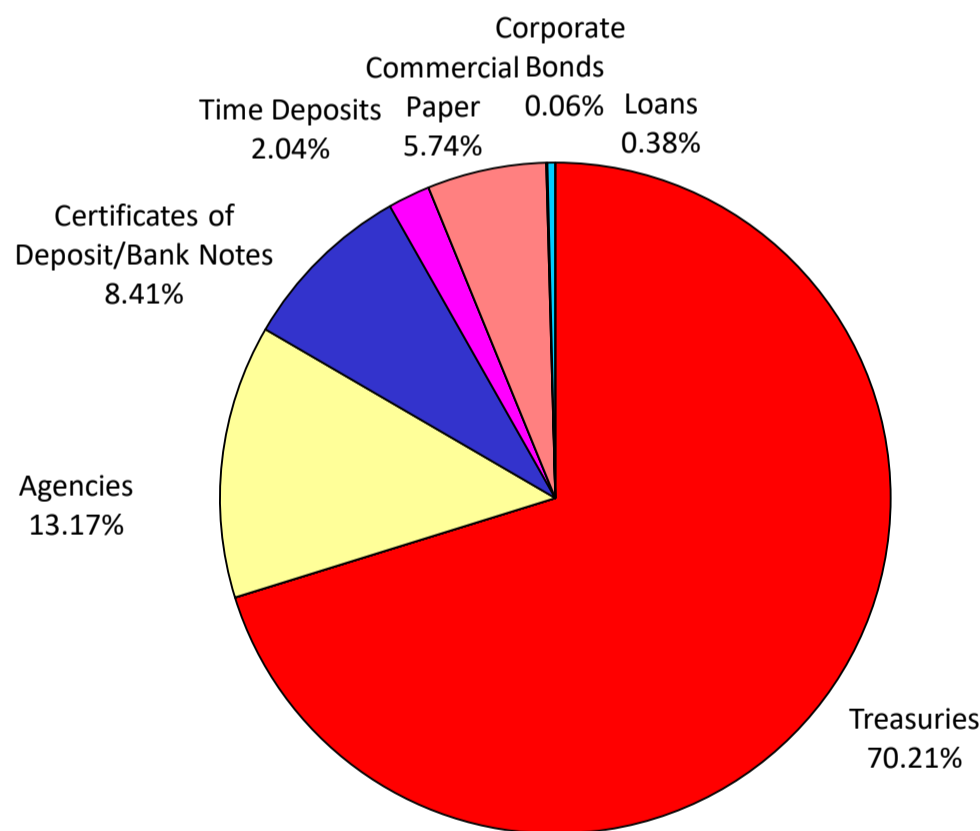

Chart does not include 0.01% of mortgages. Percentages may not total 100% due to rounding.

Daily rates are now available here. [View PMIA Daily Rates](#)

Notes: The apportionment rate includes interest earned on the CalPERS Supplemental Pension Payment pursuant to Government Code 20825 (c)(1) and interest earned on the Wildfire Fund loan pursuant to Public Utility Code 3288 (a).

Source:

<sup>(1)</sup> State of California, Office of the Treasurer

<sup>(2)</sup> State of California, Office of the Controller

**Orange County Council of Governments  
Cash Receipts/Disbursements Report  
For the Quarter ending September 30, 2021**

**Cash Receipts**

<b>Date</b>	<b>Payer</b>	<b>Description</b>	<b>Amount</b>
7/15/2021	Local Agency Investment Fund	Interest at LAIF	332.75
7/19/2021	City of Seal Beach	CDR Fees and Dues	4,904.68
7/19/2021	City of San Juan Capistrano	CDR Fees and Dues	5,712.70
7/19/2021	City of Los Alamitos	CDR Fees and Dues	3,986.60
7/19/2021	City of Laguna Woods	CDR Fees and Dues	4,306.59
7/19/2021	City of Villa Park	CDR Fees and Dues	3,575.47
7/22/2021	City of Newport Beach	CDR Fees and Dues	9,274.33
7/22/2021	City of Placentia	CDR Fees and Dues	6,806.29
7/22/2021	SVA Architecs	General Assembly Sponsorship	1,000.00
7/27/2021	OCTA	OCCOG Dues	9,000.00
7/27/2021	City of Fountain Valley	CDR Fees and Dues	7,075.20
7/27/2021	City of Yorba Linda	CDR Fees and Dues	7,992.43
7/27/2021	City of La Habra	CDR Fees and Dues	7,634.02
7/27/2021	City of Rancho Santa Margarita	CDR Fees and Dues	6,593.58
7/27/2021	City of La Palma	CDR Fees and Dues	4,264.33
7/27/2021	City of Laguna Niguel	CDR Fees and Dues	7,801.91
7/27/2021	City of Buena Park	CDR Fees and Dues	8,972.76
7/27/2021	City of Buena Park	CDR Fees and Dues	2,000.00
			101,233.64

**Cash Disbursements**

<b>Date</b>	<b>Check #</b>	<b>Payee</b>	<b>Description</b>	<b>Amount</b>
7/7/2021		Citizens Business Bank	Check re-order fees	(140.34)
7/15/2021	2118	Communications Lab	Social Media/Web Site June 2021	(2,500.00)
7/23/2021		Citizens Business Bank	Bank Fees	(20.42)
7/31/2021	2119	Aleshire & Wynder, LLP	Legal June 2021	(4,376.00)
7/31/2021	2120	CSU FAS	1st Quarter CDR Fees	(27,594.66)
7/31/2021	2121	VOID	VOID	-
7/31/2021	2122	CALCOG	Dues	(2,369.00)
7/31/2021	2123	Lisa Telles Communications	General Assembly, Special Events, REAP July 2021	(2,500.00)
7/31/2021	2124	John Hanson	Treasury Services July 2021	(980.20)
7/31/2021	2125	Kathryn Morrison	Administrative Assistant July 2021	(2,659.99)
7/31/2021	2126	Connected Consulting	July Executive Director	(11,107.24)
7/31/2021	2127	WJS Consulting	Strategy and Advocacy Services July 2021	(2,500.00)
				(56,747.85)



**AGENDA ITEM # 3**                      **OCCOG Auditor’s Communication Letter**  
**Auditor’s Communication with the Board of Directors Related to the FY 2020-21 Audit**

**STAFF RECOMMENDATION**

Receive and File.

**SUMMARY**

The CPA firm of Eide Baily, Trine, Day & Company, LLP, OCCOG’s independent auditors, is preparing to conduct its audit of OCCOG’s financial statements for FY 2020-21. In accordance with auditing standards, they have prepared the attached letter addressed to the Board of Directors that communicates certain information related to the upcoming audit.

The letter outlines the auditor’s responsibilities and the scope and timing of audit procedures to be performed, and reports are to be issued.

**ATTACHMENTS**

- A. A Letter from Eide Baily, LLP, to the OCCOG Board of Directors, dated August 16, 2021

**STAFF CONTACT**

John Hanson, CPA  
OCCOG Treasurer  
949-929-0073  
jhoccog@gmail.com

Marnie O. Primmer  
OCCOG Executive Director  
949-216-5288  
marnie@occog.com



August 16, 2021

To the Board of Directors  
Orange County Council of Governments  
Irvine, California

This letter is provided in connection with our engagement to audit the financial statements of the Orange County Council of Governments (OCCOG) as of and for the year ended June 30, 2021. Professional standards require that we communicate with you certain items including our responsibilities with regard to the financial statement audit and the planned scope and timing of our audit.

### **Our Responsibilities**

As stated in our engagement letter dated May 14, 2021, we are responsible for conducting our audit in accordance with auditing standards generally accepted in the United States of America and in accordance with *Government Auditing Standards* for the purpose of forming and expressing opinions about whether the financial statements that have been prepared by management, with your oversight, are prepared, in all material respects, in accordance with accounting principles generally accepted in the United States of America. Our audit does not relieve you or management of your respective responsibilities.

### **Planned Scope of the Audit**

Our audit will include examining, on a test basis, evidence supporting the amounts and disclosures in the financial statements; therefore, our audit will involve judgment about the number of transactions to be examined and the areas to be tested. Our audit is designed to provide reasonable, but not absolute, assurance about whether the financial statements as a whole are free of material misstatement, whether due to error, fraudulent financial reporting, misappropriation of assets, or violations of laws or governmental regulations. Because of this concept of reasonable assurance and because we will not examine all transactions, there is a risk that material misstatements may exist and not be detected by us.

Our audit will include obtaining an understanding of the entity and its environment, including its internal control, sufficient to assess the risks of material misstatement of the financial statements and as a basis for designing the nature, timing, and extent of further audit procedures. However, we will communicate to you at the conclusion of our audit, significant matters that are relevant to your responsibilities in overseeing the financial reporting process, including any material weaknesses, significant deficiencies, and violation of laws or regulations that come to our attention.

We expect to begin our audit on approximately August 2021 and issue our report by December 31, 2021.

This information is intended solely for the information and use of Board of Directors and management of OCCOG and is not intended to be and should not be used by anyone other than these specified parties.

Respectfully,

A handwritten signature in black ink that reads "Eide Bailly LLP". The signature is written in a cursive, flowing style.

Laguna Hills, California



## AGENDA ITEM # 6

## OCCOG Voting Board Member Stipend Policy

### STAFF RECOMMENDATION

Approve the proposed OCCOG Voting Board Member Stipend policy as presented or amended.

### SUMMARY

OCCOG has recently implemented a new stipend to compensate Board Members for their time and effort in attending OCCOG Board meetings. In order to ensure a smooth administration of the new program, staff is proposing a new Voting Board Member Stipend Policy for board consideration and approval. The policy will clarify who is eligible to receive the stipend, when and how stipends will be paid.

### BACKGROUND

At the June 24, 2021 OCCOG Board of Directors meeting, the Board approved the 2021-22 Budget which included the implementation of a new \$100/meeting stipend for voting OCCOG Board members who do not already receive a stipend from their organization to attend OCCOG Board meetings. The Board has discussed this matter several times over the past few years as a solution to increasing attendance among Board members to ensure quorum is achieved. Other considerations include achieving parity with other similar JPA's that members may serve on and providing acknowledgement to Board members for their dedication to the effective governance and mission of the OCCOG. OCCOG staff provided benchmarking data with other similar-sized councils of government (COGs) in the SCAG region, as well as the fiscal impact of implementing a stipend for Board members. The Board determined that a \$100 stipend per OCCOG Board meeting would be appropriate compensation for the time and effort of Directors. OCCOG is implementing a policy to ensure that Directors are compensated while minimizing the administrative impact to the OCCOG.

The following elements are proposed to be included in the policy for the OCCOG Voting Board Member Stipend:

1. OCCOG Voting Board Members are eligible to receive compensation up to \$100 per OCCOG Board of Directors meeting attended.



2. OCCOG Voting Board Members who already receive a stipend for attending OCCOG meetings from their appointing body shall not be eligible to receive a stipend from OCCOG for attending the same meeting(s).
3. Stipends shall be paid to eligible OCCOG Voting Board Members quarterly (April, July, October and January).
4. Stipends can be paid to OCCOG Voting Board Members using ACH direct deposit or check payments.
5. OCCOG Voting Board Members may opt out of receiving a stipend for attendance by notifying the Executive Director in writing that they wish to abstain from the stipend program.

## ATTACHMENTS

- A. Draft OCCOG Voting Board Member Stipend Policy

## STAFF CONTACT

John Hanson, CPA  
OCCOG Treasurer  
(949) 929-0073  
john@occog.com

Marnie O. Primmer  
OCCOG Executive Director  
(949)216-5288  
marnie@occog.com



## OCCOG VOTING BOARD MEMBER STIPEND POLICY

### SUMMARY

This policy describes compensation and related requirements for members of the Orange County Council of Governments (OCCOG) Board of Directors (Board) and alternates, pursuant to action item no. 6 dated June 24, 2021.

### BOARD AND ALTERNATE MEMBER COMPENSATION

#### Meetings of the Board

Voting members of the Board or their alternates shall be entitled to receive a stipend of \$100 for attendance at each monthly meeting of the board. Attendance is defined by either in person, or via video platform (Zoom). Meeting of the Board does not include Executive Committee Meetings. Members and alternates who are already reimbursed by their member agencies are not eligible for a stipend from OCCOG. Members may opt out the stipend at any time by informing the Executive Director in writing.

#### Remittance

Stipend payments to Board Members will be sent out quarterly. Payments are to be made within 30 days at the end of each quarter. Board members and alternates can select to be paid either via mailed check, or Electronic Transfer (ACH). Prior to first quarterly payment a completed W9 will need to be sent to the Treasurer. If payment via ACH is selected then a voided check will need to be submitted along with W9.

#### Tax Reporting

Stipend payments are considered taxable income. Payments totaling \$600 or more in a calendar year will be reported to IRS. Each Board member or alternate who receives an amount \$600 or greater in the calendar year will be sent from OCCOG a 1099 NEC within 30 days after new year.

Effective Date: August 26, 2021





## AGENDA ITEM # 7

## LEGISLATIVE UPDATE

### STAFF RECOMMENDATION

Approve the following recommended positions on legislation: Oppose AB 339, Support AB 361, Oppose AB 672, and Oppose AB 989.

### SUMMARY

The Legislative Update is provided to keep the OCCOG Board apprised of legislative and regulatory actions that address land use and housing, energy, mobility, air quality and water issues.

### BACKGROUND

#### STATE UPDATE

#### *2021 State Legislative Calendar – Remaining Key Dates*

August 27 – Fiscal Committee Deadline  
August 30 – September 10 – Floor Session Only  
September 3 – Last Day to Amend Bills  
September 10 – Last Day to Pass Bills

#### *Housing Element Update*

On July 1, 2021, OCCOG sent a letter requesting a 6-month extension to the October Housing Element deadline to the Orange County delegation and Legislative Leadership. Several Member Agencies, Assembly Member Quirk-Silva, and other partners have shared with us that they have also sent similar letters.

At this time, conversations with the Governor’s Office and the Department of Housing and Community Development (HCD) have not yielded support for an extension. In the initial conversations, concerns were expressed about a a blanket extension for all cities. The Southern California Association of Governments worked to develop a draft checklist to assist HCD in determining which agencies have made good faith efforts to meet the deadline but are simply unable to do so.



As part of the budget process, a number of trailer bills have moved ahead and there are several more that could still advance before the end of session. The main housing trailer bill was AB 140, which moved forward without the Housing Element Extension included.

At this point, the only remaining vehicle for the extension would be in another budget trailer bill but it is not yet clear that this is likely.

SCAG is working with the Southern California delegation to work with Budget Committee Leadership to determine if there is a path forward before the end of session.

The Legislature returns on August 16<sup>th</sup> from Summer Recess so there may be additional developments to report out soon.

### *State Bills of Interest*

The following bills of interest are proposed for consideration by the OCCOG Board of Directors.

#### **AB 339 (Lee, D-San Jose) Local government: open and public meetings**

AB 339 applies to jurisdictions over 250,000 and would require cities and counties to provide both in-person and remote participation opportunities to allow members of the public to participate in open and public meetings. All applicable meetings with a remote participation option will be required to provide a two-way telephonic or internet-based option for members of the public with the same time allotment given to in-person comments. If the local agency, as of June 15, 2021 provided a video streaming option, it must also continue to do so. Additionally, if in-person attendance is prohibited due to a state of emergency, all meetings must provide some kind of in-person commenting opportunity. The location of this opportunity must be included in the meeting agenda posting. AB 339 is proposed to sunset on December 31, 2023.

Under AB 339, teleconferencing provisions return to existing law which requires a posted agenda and publicly accessible teleconference locations. While AB 339 attempts to provide opportunities for long term flexibility for remote participation, limiting the bill to only cities over 250,000 would result in a patchwork of public participation rules across the state causing confusion amongst the members of the public who wish to participate. Additionally, this bill does not allow remote participation of the policy makers and thus does not meet OCCOG's needs at this time.



AB 339 is currently supported by the League of Women Voters of California, California League of Conservation Voters, NextGen Policy, California News Publishers Association, First Amendment Coalition, People for Housing – Orange County, and Housing is a Human Right – Orange County.

The bill is opposed by the League of California Cities, the California Special Districts Association, California School Boards Association, Orange County Water District, City of Yorba Linda, and the Urban Counties of California.

*Staff Recommendation: Oppose*

**AB 361 (Rivas, D-Hollister) Open meetings: local agencies: teleconferences**

AB 361 would allow a local agency to use teleconferencing without complying with the Brown Act's physical access and quorum requirements for teleconferenced meetings when state or local officials have imposed or recommended social distancing measures or where attendance in-person during a state of emergency is determined to be an imminent risk to health or safety. In order for this to be permitted, the legislative body must give notice of the meeting, allow the public to address the legislative body, and provide either a teleconference or internet based remote commenting opportunity for the public. In the event the remote participation technology is disrupted, the legislative body can take no action until the service is restored.

To continue this ability, the legislative body must reaffirm the need to continue teleconferencing every 30 days. While this bill meets the needs for local agencies operating under emergency conditions, it does not fully meet the needs of OCCOG to continue to provide remote participation opportunities on an ongoing basis. However, of the two proposals, this one most directly addresses OCCOG's needs, even if on a temporary basis.

AB 361 is supported by the California Special Districts Association, Association of California Water Agencies, California State Association of Counties, California Municipal Utilities Association, League of California Cities, Costa Mesa Sanitary District, Orange County Employees Association, Orange County Local Agency Formation Commission, and the Orange County Water District.

*Staff Recommendation: Support*

**AB 672 (Garcia, D-Bell Gardens) Planning and zoning law: rezoning reauthorization: golf courses**

AB 672 would require a local agency to rezone sites used as a golf course to also allow for residential and open-space use by the end of the 6<sup>th</sup> RHNA cycle. Rezoning performed under these provisions



would also be exempt from the California Environmental Quality Act (CEQA) and would apply if the golf course is in a park-poor area, if it owned by the local jurisdiction or is in a high-density area.

AB 672 was held in its first policy committee without a hearing and is a two-year bill. This bill cannot be considered again until January 2022 and there is not currently urgent action needed. However, the Board may wish to take a position now so that when the bill is eligible to be heard again OCCOG will have an established position on the bill. As the bill unnecessarily intrudes into local land use authority, this bill is not consistent with OCCOG's Legislative Platform.

There is currently no registered support or opposition to the bill.

*Staff Recommendation: Oppose*

#### **AB 989 (Gabriel, D-) Housing Accountability Act: appeals: Office of Housing Appeals**

AB 989 creates the Housing Accountability Committee (HAC) to review appeals of affordable housing projects denied by a local government and to approve those projects if the denial violates the Housing Accountability Act (HAA). The HAC would also receive appeals from applicants when the applicant feels an approved development is subject to conditions that would render the project economically infeasible.

Applicable projects include housing developments where at least 20% of the housing units will house lower income households or developments where 100% of the units will be occupied by moderate income households. The applicants have 30 days from the date of the local agency's initial decision to notify the local agency that they intend to file an appeal with the HAC. The local agency will then have 60 days to resolve the issue before the appeal is filed, including holding a hearing within 30 days of the notice of intent.

If the HAC determines that the local agency's decision was in violation of the Housing Accountability Act, the HAC may vacate the decision and require the local agency to issue the necessary approvals or remove infeasible conditions. The local agency must take corrective action within 30 days.

The most recent version of the bill requires that developers use this process before pursuing civil action, however the timelines currently in the bill may also inadvertently preclude other civil actions by the developer due to the statute of limitations.

AB 989 unnecessarily intrudes into local land use authority, removes important public protection considerations, and ignores the input of local communities where these projects may be located.



The State is unlikely to be able to adequately judge approvals and conditions of approval for each individual jurisdiction throughout the state. Lastly, there is already an existing legal process to consider these appeals and there is not a demonstrated need for additional administrative hurdles.

AB 989 is sponsored by the California Apartment Association, and the California Housing Partnership. It is further supported by the Bay Area Council, National Resources Defense Council, the Valley Industry & Commerce Association, and Abundant Housing LA. Recent amendments have caused the California Association of Realtors, the Corporation for Supportive Housing, Housing California, the Non-Profit Housing Association of Northern California, Rural Community Assistance Corporation, and the Southern California Association of Non-Profit Housing to withdraw their support for the bill.

Ab 989 is opposed by the League of California Cities, California State Association of Counties, the Association of California Cities – Orange County (ACC-OC), California Building Industry Association, the City of Laguna Niguel, the South Bay Cities Council of Governments, California Rural Legal Assistance Foundation, California YIMBY, Habitat for Humanity California, Housing Action Coalition, Greenbelt Alliance, Public Interest Law Project, and the Western Center on Law and Poverty.

*Staff Recommendation: Oppose*

## ATTACHMENTS

- A. OCCOG Bills with Positions
- B. OCCOG All Tracked Bills

## STAFF CONTACTS

Wendy J. Strack  
OCCOG Legislative Consultant  
951-712-3173  
wendy@wjsconsult.com

Marnie O. Primmer  
OCCOG Executive Director  
949-216-5288  
marnie@occog.com

## Attachment A OCCOG Bills with Positions

**[AB 339](#) (Lee D) Local government: open and public meetings.**

**Last Amend:** 7/5/2021

**Status:** 8/17/2021-Read second time. Ordered to third reading.

**Is Fiscal:** Y

**Location:** 8/17/2021-S. THIRD READING

Desk	Policy	Fiscal	Floor	Desk	Policy	Fiscal	Floor	Conf. Conc.	Enrolled	Vetoed	Chaptered
1st House				2nd House							

**Summary:** The Ralph M. Brown Act requires, with specified exceptions, that all meetings of a legislative body of a local agency, as those terms are defined, be open and public and that all persons be permitted to attend and participate. Under existing law, a member of the legislative body who attends a meeting where action is taken in violation of this provision, with the intent to deprive the public of information that the member knows the public is entitled to, is guilty of a crime. This bill would require local agencies to conduct meetings subject to the act consistent with applicable state and federal civil rights laws, as specified.

**Notes:** OCCOG - Proposed Oppose Position  
 OCTA - Neutral  
 ACCOC - Oppose  
 League of California Cities - Oppose  
 Transportation Corridor Agencies - Oppose

**[AB 361](#) (Rivas, Robert D) Open meetings: local agencies: teleconferences.**

**Last Amend:** 7/6/2021

**Status:** 7/15/2021-Read second time. Ordered to third reading.

**Is Fiscal:** N

**Location:** 7/15/2021-S. THIRD READING

Desk	Policy	Fiscal	Floor	Desk	Policy	Fiscal	Floor	Conf. Conc.	Enrolled	Vetoed	Chaptered
1st House				2nd House							

**Summary:** Existing law, the Ralph M. Brown Act requires, with specified exceptions, that all meetings of a legislative body of a local agency, as those terms are defined, be open and public and that all persons be permitted to attend and participate. This bill, until January 1, 2024, would authorize a local agency to use teleconferencing without complying with the teleconferencing requirements imposed by the Ralph M. Brown Act when a legislative body of a local agency holds a meeting during a declared state of emergency, as that term is defined, when state or local health officials have imposed or recommended measures to promote social distancing during a proclaimed state of emergency held for the purpose of determining, by majority vote, whether meeting in person would present imminent risks to the health or safety of attendees, and during a proclaimed state of emergency when the legislative body has determined that meeting in person would present imminent risks to the health or safety of attendees, as provided.

**Notes:** OCCOG - Proposed Support Position  
 League of California Cities - Support

**[AB 617](#) (Davies R) Planning and zoning: regional housing needs: exchange of allocation.**

**Status:** 5/7/2021-Failed Deadline pursuant to Rule 61(a)(3). (Last location was H. & C.D. on 2/25/2021)(May be acted upon Jan 2021)

**Is Fiscal:** N

**Location:** 5/7/2021-A. 2 YEAR

Desk	2 year	Fiscal	Floor	Desk	Policy	Fiscal	Floor	Conf. Conc.	Enrolled	Vetoed	Chaptered
1st House				2nd House							

**Summary:** Would authorize a city or county, by agreement, to transfer all or a portion of its allocation of regional housing need to another city or county. The bill would allow the transferring city to pay the transferee city or county an amount determined by that agreement, as well as a surcharge to offset the impacts and associated costs of the additional housing on the transferee city. The bill would also require the transferring city or county and the transferee city or county to report to the council of governments and the department specified information about the transfer, as provided.

**Notes:**  
 OCCOG - Support  
 ACCOC - Support

**[AB 672](#) (Garcia, Cristina D) Planning and zoning law: rezoning authorization: golf courses.**

**Last Amend:** 4/6/2021

**Status:** 4/30/2021-Failed Deadline pursuant to Rule 61(a)(2). (Last location was H. & C.D. on

3/18/2021)(May be acted upon Jan 2022)

**Is Fiscal:** Y

**Location:** 4/30/2021-A. 2 YEAR

Desk	2 year	Fiscal	Floor	Desk	Policy	Fiscal	Floor	Conf. Conc.	Enrolled	Vetoed	Chaptered
1st House				2nd House							

**Summary:** Would require a city, county, or city and county to rezone, by the date the 6th regional housing needs assessment cycle applicable to the city, county, or city and county ends, certain sites used as a golf course to also allow for residential and open-space use in accordance with specified requirements. The bill would exempt any ordinance, resolution, general or specific plan amendment, or other action necessary of the city, county, or city and county to rezone a site pursuant to the bill's provisions from CEQA. The bill would require a development on a site that is rezoned for residential and open-space use pursuant to the bill's provisions to comply with specified requirements, including that 25 percent of all units developed on the site be available for persons and families of low income for a period of at least 45 years for owner-occupied units and at least 55 years for rental units, and that a certain unit per acre density be met.

**Notes:** OCCOG - Proposed Oppose Position

**AB 687**

**(Seyarto R) Joint powers authorities: Riverside County Housing Finance Trust.**

**Status:** 7/23/2021-Approved by the Governor. Chaptered by Secretary of State - Chapter 120, Statutes of 2021.

**Is Fiscal:** N

**Location:** 7/23/2021-A. CHAPTERED

Desk	Policy	Fiscal	Floor	Desk	Policy	Fiscal	Floor	Conf. Conc.	Enrolled	Vetoed	Chaptered
1st House				2nd House							

**Summary:** Would authorize the creation of the Western Riverside County Housing Finance Trust, a joint powers authority, for the purposes of funding housing specifically assisting the homeless population and persons and families of extremely low, very low, and low income within the County of Riverside as specified.

**Notes:**

OCCOG - Support

SCAG - Support

**AB 787**

**(Gabriel D) Planning and zoning: housing element: converted affordable housing units.**

**Last Amend:** 5/3/2021

**Status:** 8/16/2021-In committee: Referred to suspense file.

**Is Fiscal:** Y

**Location:** 8/16/2021-S. APPR. SUSPENSE FILE

Desk	Policy	Fiscal	Floor	Desk	Policy	Fiscal	Floor	Conf. Conc.	Enrolled	Vetoed	Chaptered
1st House				2nd House							

**Summary:** Current law requires the planning agency of a city or county to provide an annual report that includes specified information by April 1 of each year to specified entities, including the Department of Housing and Community Development. Among other things, existing law requires that this report include the progress in meeting the city's or county's share of regional housing needs and local efforts to remove governmental constraints to the maintenance, improvement, and development of housing, as specified. This bill would authorize a planning agency to include in its annual report the number of units in an existing multifamily building that were converted to deed-restricted rental housing for very low, low-, or moderate-income households by the imposition of affordability covenants and restrictions for the unit.

**Notes:**

OCCOG - Support

ACCOC - Support

**AB 816**

**(Chiu D) Homelessness: Housing Trust Fund: housing projects.**

**Last Amend:** 7/16/2021

**Status:** 8/16/2021-In committee: Hearing postponed by committee.

**Is Fiscal:** Y

**Location:** 7/7/2021-S. APPR.

Desk	Policy	Fiscal	Floor	Desk	Policy	Fiscal	Floor	Conf. Conc.	Enrolled	Vetoed	Chaptered
1st House				2nd House							

**Summary:** Current federal law requires the Secretary of the United States Department of Housing and Urban Development to establish a Housing Trust Fund to provide grants to states to increase the supply of rental housing for extremely low and very low income families, including homeless families, and home ownership for extremely low and very low income families. Current law requires the department to collaborate with the California Housing Finance Agency to develop an allocation plan to demonstrate how the funds will be distributed, based on the priority housing needs identified in the

state's consolidated plan, and to convene a stakeholder process to inform the development of the plan. Current law requires the allocation plan and program guidelines to prioritize projects based on enumerated factors such as the extent to which project rents are affordable. The department is required to submit this plan to the Assembly Committee on Housing and Community Development and the Senate Transportation and Housing Committees 30 days after receipt of the federal funds. This bill would require the department to prioritize funding for projects that serve people experiencing homelessness, to the extent that a sufficient number of projects exist.

**Notes:** OCCOG - Oppose  
League of California Cities - Oppose

**AB 989 (Gabriel D) Housing Accountability Act: appeals: Office of Housing Appeals.**

**Last Amend:** 8/18/2021

**Status:** 8/18/2021-From committee chair, with author's amendments: Amend, and re-refer to committee. Read second time, amended, and re-referred to Com. on APPR.

**Is Fiscal:** Y

**Location:** 7/8/2021-S. APPR.

Desk	Policy	Fiscal	Floor	Desk	Policy	Fiscal	Floor	Conf. Conc.	Enrolled	Vetoed	Chaptered
1st House				2nd House							

**Summary:** The Housing Accountability Act prohibits a local agency from disapproving, or conditioning approval in a manner that renders infeasible, specified housing development projects, including projects for very low, low-, or moderate-income households and projects for emergency shelters that comply with applicable, objective general plan, zoning, and subdivision standards and criteria in effect at the time the application for the project is deemed complete, unless the local agency makes specified written findings based on a preponderance of the evidence in the record. This bill would, until January 1, 2029, establish an Office of Housing Appeals (office) within the department, administered by the director of the department, to review housing development projects that are alleged to have been denied or subject to conditions in violation of the Housing Accountability Act. The bill would establish housing appeals panels, consisting of administrative law judges with specified qualifications, within the office.

**Notes:** OCCOG - Proposed Oppose Position  
League of California Cities - Oppose

**AB 1258 (Nguyen R) Housing element: regional housing need plan: judicial review.**

**Last Amend:** 3/22/2021

**Status:** 4/30/2021-Failed Deadline pursuant to Rule 61(a)(2). (Last location was H. & C.D. on 3/4/2021)(May be acted upon Jan 2022)

**Is Fiscal:** Y

**Location:** 4/30/2021-A. 2 YEAR

Desk	2 year	Fiscal	Floor	Desk	Policy	Fiscal	Floor	Conf. Conc.	Enrolled	Vetoed	Chaptered
1st House				2nd House							

**Summary:** Under current law the Department of Housing and Community Development, in consultation with each council of governments, determines each region's existing and projected housing needs. Under existing law, upon making that determination, the council of governments may object to the determination, and the department is required to respond to an objection by making a final written determination. Current law requires that, based on the determination of the department, a council of governments, or for cities and counties without a council of governments, the department, adopts a final regional housing need plan that allocates a share of the regional housing need to each locality in the region. This bill would subject the department's final written determination of a region's housing needs to judicial review in an action brought by the council of governments. The bill would also subject the final regional housing need plan adopted by the council of governments or the department, as the case may be, to judicial review.

**Notes:**  
OCCOG - Support  
ACCOC - Support

**SB 5 (Atkins D) Affordable Housing Bond Act of 2022.**

**Last Amend:** 3/10/2021

**Status:** 3/18/2021-Re-referred to Coms. on HOUSING and GOV. & F.

**Is Fiscal:** Y

**Location:** 3/18/2021-S. HOUSING

Desk	Policy	Fiscal	Floor	Desk	Policy	Fiscal	Floor	Conf. Conc.	Enrolled	Vetoed	Chaptered
1st House				2nd House							

**Summary:** Would enact the Affordable Housing Bond Act of 2022, which, if adopted, would authorize the issuance of bonds in the amount of \$6,500,000,000 pursuant to the State General Obligation Bond Law. Proceeds from the sale of these bonds would be used to fund affordable rental housing and



homeownership programs. The bill would state the intent of the Legislature to determine the allocation of those funds to specific programs. This bill would provide for submission of the bond act to the voters at the November 8, 2022, statewide general election in accordance with specified law.

**Notes:** OCCOG - Watch  
 ACCOC - Watch  
 SCAG - Support

**SB 6 (Caballero D) Local planning: housing: commercial zones.**

**Last Amend:** 4/12/2021

**Status:** 7/14/2021-Failed Deadline pursuant to Rule 61(a)(11). (Last location was DESK on 5/24/2021) (May be acted upon Jan 2022)

**Is Fiscal:** Y

**Location:** 7/14/2021-A. 2 YEAR

Desk	Policy	Fiscal	Floor	2 year	Policy	Fiscal	Floor	Conf. Conc.	Enrolled	Vetoed	Chaptered
1st House				2nd House							

**Summary:** The Planning and Zoning Law requires each county and city to adopt a comprehensive, long-term general plan for its physical development, and the development of certain lands outside its boundaries, that includes, among other mandatory elements, a housing element. This bill, the Neighborhood Homes Act, would deem a housing development project, as defined, an allowable use on a neighborhood lot, which is defined as a parcel within an office or retail commercial zone that is not adjacent to an industrial use. The bill would require the density for a housing development under these provisions to meet or exceed the density deemed appropriate to accommodate housing for lower income households according to the type of local jurisdiction, including a density of at least 20 units per acre for a suburban jurisdiction.

**Notes:** OCCOG - Oppose  
 ACCOC - Oppose  
 OCBC - Support If Amended  
 SCAG - Watch

**SB 7 (Atkins D) Environmental quality: Jobs and Economic Improvement Through Environmental Leadership Act of 2021.**

**Last Amend:** 2/18/2021

**Status:** 5/20/2021-Approved by the Governor. Chaptered by Secretary of State. Chapter 19, Statutes of 2021.

**Is Fiscal:** Y

**Location:** 5/20/2021-S. CHAPTERED

Desk	Policy	Fiscal	Floor	Desk	Policy	Fiscal	Floor	Conf. Conc.	Enrolled	Vetoed	Chaptered
1st House				2nd House							

**Summary:** Would enact the Jobs and Economic Improvement Through Environmental Leadership Act of 2021, which would reenact the former leadership act, with certain changes, and would authorize the Governor, until January 1, 2024, to certify projects that meet specified requirements for streamlining benefits related to CEQA. The bill would additionally include housing development projects, as defined, meeting certain conditions as projects eligible for certification. The bill would, except for those housing development projects, require the quantification and mitigation of the impacts of a project from the emissions of greenhouse gases, as provided. The bill would revise and recast the labor-related requirements for projects undertaken by both public agencies and private entities. The bill would provide that the Governor is authorized to certify a project before the lead agency certifies the final EIR for the project.

**Notes:**  
 OCCOG - Support  
 SCAG - Support  
 ACCOC - Watch

**SB 8 (Skinner D) Housing Crisis Act of 2019.**

**Last Amend:** 7/5/2021

**Status:** 8/19/2021-From committee: Do pass. (Ayes 16. Noes 0.) (August 19).

**Is Fiscal:** Y

**Location:** 7/1/2021-A. APPR.

Desk	Policy	Fiscal	Floor	Desk	Policy	Fiscal	Floor	Conf. Conc.	Enrolled	Vetoed	Chaptered
1st House				2nd House							

**Summary:** Would clarify, for various purposes of the Housing Crisis Act of 2019, that "housing development project" includes projects that involve no discretionary approvals, projects that involve both discretionary and nondiscretionary approvals, and projects that include a proposal to construct a single dwelling unit. The bill would specify that this clarification is declaratory of existing law.

**Notes:**

OCCOG - Watch  
 BIA - Support  
 ACCOC - Oppose

**SB 9**

**(Atkins D) Housing development: approvals.**

**Last Amend:** 8/16/2021

**Status:** 8/19/2021-From committee: Do pass. (Ayes 12. Noes 1.) (August 19).

**Is Fiscal:** Y

**Location:** 6/22/2021-A. APPR.

Desk	Policy	Fiscal	Floor	Desk	Policy	Fiscal	Floor	Conf. Conc.	Enrolled	Vetoed	Chaptered
1st House				2nd House							

**Summary:** The Planning and Zoning Law provides for the creation of accessory dwelling units by local ordinance, or, if a local agency has not adopted an ordinance, by ministerial approval, in accordance with specified standards and conditions. This bill, among other things, would require a proposed housing development containing no more than 2 residential units within a single-family residential zone to be considered ministerially, without discretionary review or hearing, if the proposed housing development meets certain requirements, including, but not limited to, that the proposed housing development would not require demolition or alteration of housing that is subject to a recorded covenant, ordinance, or law that restricts rents to levels affordable to persons and families of moderate, low, or very low income, that the proposed housing development does not allow for the demolition of more than 25% of the existing exterior structural walls, except as provided, and that the development is not located within a historic district, is not included on the State Historic Resources Inventory, or is not within a site that is legally designated or listed as a city or county landmark or historic property or district.

**Notes:** OCCOG - Oppose  
 ACCOC - Oppose  
 League of California Cities - Oppose  
 SCAG - Oppose Unless Amended  
 OCBC - Support

**SB 10**

**(Wiener D) Planning and zoning: housing development: density.**

**Last Amend:** 7/5/2021

**Status:** 7/6/2021-Read second time. Ordered to third reading.

**Is Fiscal:** N

**Location:** 7/6/2021-A. THIRD READING

Desk	Policy	Fiscal	Floor	Desk	Policy	Fiscal	Floor	Conf. Conc.	Enrolled	Vetoed	Chaptered
1st House				2nd House							

**Summary:** Would, notwithstanding any local restrictions on adopting zoning ordinances, authorize a local government to adopt an ordinance to zone any parcel for up to 10 units of residential density per parcel, at a height specified in the ordinance, if the parcel is located in a transit-rich area or an urban infill site, as those terms are defined. The bill would prohibit a local government from adopting an ordinance pursuant to these provisions on or after January 1, 2029. The bill would specify that an ordinance adopted under these provisions, and any resolution to amend the jurisdiction's General Plan, ordinance, or other local regulation adopted to be consistent with that ordinance, is not a project for purposes of the California Environmental Quality Act. The bill would prohibit an ordinance adopted under these provisions from superceding a local restriction enacted or approved by a local initiative that designates publicly owned land as open-space land or for park or recreational purposes.

**Notes:**  
 OCCOG - Oppose Unless Amended  
 ACCOC - Watch  
 SCAG - Support If Amended  
 OCBC - Support

**SB 12**

**(McGuire D) Local government: planning and zoning: wildfires.**

**Last Amend:** 7/1/2021

**Status:** 7/14/2021-Failed Deadline pursuant to Rule 61(a)(11). (Last location was H. & C.D. on 6/24/2021)(May be acted upon Jan 2022)

**Is Fiscal:** Y

**Location:** 7/14/2021-A. 2 YEAR

Desk	Policy	Fiscal	Floor	Desk	2 year	Fiscal	Floor	Conf. Conc.	Enrolled	Vetoed	Chaptered
1st House				2nd House							

**Summary:** Current law requires that the Office of Planning and Research, among other things, coordinate with appropriate entities, including state, regional, or local agencies, to establish a clearinghouse for climate adaptation information for use by state, regional, and local entities, as provided. This bill would require the safety element, upon the next revision of the housing element or the hazard mitigation plan, on or after July 1, 2024, whichever occurs first, to be reviewed and

updated as necessary to include a comprehensive retrofit strategy to reduce the risk of property loss and damage during wildfires, as specified, and would require the planning agency to submit the adopted strategy to the Office of Planning and Research for inclusion into the above-described clearinghouse.

**Notes:**

- OCCOG - Oppose Unless Amended
- BIA - Oppose Unless Amended
- OCBC - Oppose Unless Amended

**SB 15**

**(Portantino D) Housing development: incentives: rezoning of idle retail sites.**

**Last Amend:** 5/20/2021

**Status:** 7/14/2021-Failed Deadline pursuant to Rule 61(a)(11). (Last location was DESK on 6/1/2021) (May be acted upon Jan 2022)

**Is Fiscal:** Y

**Location:** 7/14/2021-A. 2 YEAR

Desk	Policy	Fiscal	Floor	2 year	Policy	Fiscal	Floor	Conf. Conc.	Enrolled	Vetoed	Chaptered
1st House				2nd House							

**Summary:** Current law establishes, among other housing programs, the Workforce Housing Reward Program, which requires the Department of Housing and Community Development to make local assistance grants to cities, counties, and cities and counties that provide land use approval to housing developments that are affordable to very low and low-income households. This bill, upon appropriation by the Legislature in the Budget Act or other act, would require the department to administer a program to provide incentives in the form of grants allocated as provided to local governments that rezone idle sites used for a big box retailer or a commercial shopping center to instead allow the development of housing, as defined.

**Notes:**

- OCCOG - Support
- ACCOC - Support
- OCBC - Watch
- SCAG - Support
- League of California Cities - Support

**SB 261**

**(Allen D) Regional transportation plans: sustainable communities strategies.**

**Status:** 4/30/2021-Failed Deadline pursuant to Rule 61(a)(2). (Last location was TRANS. on 3/15/2021) (May be acted upon Jan 2022)

**Is Fiscal:** Y

**Location:** 4/30/2021-S. 2 YEAR

Desk	2 year	Fiscal	Floor	Desk	Policy	Fiscal	Floor	Conf. Conc.	Enrolled	Vetoed	Chaptered
1st House				2nd House							

**Summary:** current law requires certain transportation planning agencies to prepare and adopt a regional transportation plan directed at achieving a coordinated and balanced regional transportation system. Certain of these agencies are designated under federal law as metropolitan planning organizations. Existing law requires that each regional transportation plan include a sustainable communities strategy developed to achieve greenhouse gas emission reduction targets for the automobile and light truck sector for 2020 and 2035 established by the State Air Resources Board. This bill would require that the sustainable communities strategy be developed to additionally achieve greenhouse gas emission reduction targets for the automobile and light truck sector for 2045 and 2050 and vehicle miles traveled reduction targets for 2035, 2045, and 2050 established by the board. The bill would make various conforming changes to integrate those additional targets into regional transportation plans.

**Notes:**

- OCCOG - Oppose Unless Amended
- SCAG - Oppose Unless Amended
- OCTA - Oppose Unless Amended
- OCBC - Oppose
- CALCOG - Oppose
- BIA - Oppose
- ACCOC - Oppose

**SB 478**

**(Wiener D) Planning and Zoning Law: housing development projects.**

**Last Amend:** 7/5/2021

**Status:** 8/19/2021-August 19 set for first hearing. Placed on suspense file.

**Is Fiscal:** Y

**Location:** 8/19/2021-A. APPR. SUSPENSE FILE

Desk	Policy	Fiscal	Floor	Desk	Policy	Fiscal	Floor	Conf. Conc.	Enrolled	Vetoed	Chaptered
1st House				2nd House							

**Summary:** The Planning and Zoning Law requires the Department of Housing and Community

Development to notify the city, county, or city and county, and authorizes the department to notify the Attorney General, that the city, county, or city and county is in violation of state law if the department finds that the housing element or an amendment to that element, or any specified action or failure to act, does not substantially comply with the law as it pertains to housing elements or that any local government has taken an action in violation of certain housing laws. This bill would prohibit a local agency, as defined, from imposing a floor-to-area ratio standard that is less than 1.0 on a housing development project that consists of 3 to 7 units, or less than 1.25 on a housing development project that consists of 8 to 10 units. The bill would prohibit a local agency from imposing a lot coverage requirement that would physically preclude a housing development project from achieving the floor-to-area ratios described above.

**Notes:**

OCCOG - Oppose

ACCOC - Oppose

**SB 623 (Newman D) Electronic toll and transit fare collection systems.**

**Status:** 4/30/2021-Failed Deadline pursuant to Rule 61(a)(2). (Last location was JUD. on 4/13/2021) (May be acted upon Jan 2022)

**Is Fiscal:** Y

**Location:** 4/30/2021-S. 2 YEAR

Desk	2 year	Fiscal	Floor	Desk	Policy	Fiscal	Floor	Conf. Conc.	Enrolled	Vetoed	Chaptered
1st House				2nd House							

**Summary:** Current law requires the Department of Transportation, in cooperation with the Golden Gate Bridge, Highway and Transportation District and all known entities planning to implement a toll facility, to develop and adopt functional specifications and standards for an automatic vehicle identification system in compliance with specified objectives, and generally requires any automatic vehicle identification system purchased or installed after January 1, 1991, to comply with those specifications and standards. Current law authorizes operators of toll facilities on federal-aid highways engaged in an interoperability program to provide only specified information regarding a vehicle's use of the toll facility. This bill would authorize those operators to provide instead only the information specified in functional specifications and standards adopted by the department and operators of toll facilities in this state on federal-aid highways for purposes of interstate interoperability.

**Notes:**

OCCOG - Support

OCTA - Support

OCBC - Support

TCA - Support

SCAG - Support

**SB 765 (Stern D) Accessory dwelling units: setbacks.**

**Status:** 4/30/2021-Failed Deadline pursuant to Rule 61(a)(2). (Last location was HOUSING on 3/3/2021)(May be acted upon Jan 2022)

**Is Fiscal:** Y

**Location:** 4/30/2021-S. 2 YEAR

Desk	2 year	Fiscal	Floor	Desk	Policy	Fiscal	Floor	Conf. Conc.	Enrolled	Vetoed	Chaptered
1st House				2nd House							

**Summary:** The Planning and Zoning Law, among other things, provides for the creation of accessory dwelling units by local ordinance, or, if a local agency has not adopted an ordinance, by ministerial approval, in accordance with specified standards and conditions. Current law prohibits a local agency's accessory dwelling unit ordinance from imposing a setback requirement of more than 4 feet from the side and rear lot lines for an accessory dwelling unit that is not converted from an existing structure or a new structure constructed in the same location and to the same dimensions as an existing structure. This bill would remove the above-described prohibition on a local agency's accessory dwelling unit ordinance, and would instead provide that the rear and side yard setback requirements for accessory dwelling units may be set by the local agency. The bill would authorize an accessory dwelling unit applicant to submit a request to the local agency for an alternative rear and side yard setback requirement if the local agency's setback requirements make the building of the accessory dwelling unit infeasible.

**Notes:**

OCCOG - Support

League of California Cities - Support

**Total Measures: 21**

**Total Tracking Forms: 21**

## Attachment B OCCOG All Tracked Bills

**AB 68**

**(Quirk-Silva D) Department of Housing and Community Development: California Statewide Housing Plan: annual reports.**

**Last Amend:** 7/12/2021

**Status:** 8/16/2021-In committee: Referred to suspense file.

**Is Fiscal:** Y

**Location:** 8/16/2021-S. APPR. SUSPENSE FILE

Desk	Policy	Fiscal	Floor	Desk	Policy	Fiscal	Floor	Conf. Conc.	Enrolled	Vetoed	Chaptered
1st House				2nd House							

**Summary:** Current law establishes the California Statewide Housing Plan, which serves as a state housing plan for all relevant purposes, that incorporates a statement of housing goals, policies, and objectives, as well as specified segments. Current law requires the Department of Housing and Community Development to update and provide a revision of the plan to the Legislature every 4 years, as provided. This bill would revise and recast those provisions related to the California Statewide Housing Plan. The bill would, starting with any update or revision to the plan on or after January 1, 2023, require the plan to include specified information, including, among other things, an inventory number of affordable units needed to meet the state's affordable housing needs and an identification of strategies to help individuals experiencing homelessness.

**AB 71**

**(Rivas, Luz D) Homelessness funding: Bring California Home Act.**

**Last Amend:** 5/24/2021

**Status:** 6/3/2021-Ordered to inactive file at the request of Assembly Member Luz Rivas.

**Is Fiscal:** Y

**Location:** 6/3/2021-A. INACTIVE FILE

Desk	Policy	Fiscal	Floor	Desk	Policy	Fiscal	Floor	Conf. Conc.	Enrolled	Vetoed	Chaptered
1st House				2nd House							

**Summary:** The Personal Income Tax Law, in conformity with federal income tax law, generally defines gross income as income from whatever source derived, except as specifically excluded, and provides various exclusions from gross income. Current federal law, for purposes of determining a taxpayer's gross income for federal income taxation, requires that a person who is a United States shareholder of any controlled foreign corporation to include in their gross income the global intangible low-taxed income for that taxable year, as provided. This bill, for taxable years beginning on or after January 1, 2022, would include a taxpayer's global intangible low-taxed income in their gross income for purposes of the Personal Income Tax Law, in modified conformity with the above-described federal provisions.

**Notes:**

ACCOC - Watch

OCBC - Oppose

**AB 72**

**(Petrie-Norris D) Environmental protection: coastal adaptation projects: natural infrastructure: regulatory review and permitting: report.**

**Last Amend:** 6/28/2021

**Status:** 8/16/2021-In committee: Referred to suspense file.

**Is Fiscal:** Y

**Location:** 8/16/2021-S. APPR. SUSPENSE FILE

Desk	Policy	Fiscal	Floor	Desk	Policy	Fiscal	Floor	Conf. Conc.	Enrolled	Vetoed	Chaptered
1st House				2nd House							

**Summary:** Would enact the Coastal Adaptation Permitting Act of 2021. The bill would require the Natural Resources Agency to explore, and authorize it to implement, options within the agency's jurisdiction to establish a more coordinated and efficient regulatory review and permitting process for coastal adaptation projects that use natural infrastructure, as defined. The bill would require the agency to submit, by July 1, 2023, a report to the Legislature with suggestions and recommendations for improving and expediting the coordination between appropriate agencies in their regulatory review and permitting process for coastal adaptation projects that use natural infrastructure.

**Notes:**

ACCOC - Watch

**AB 106**

**(Salas D) Regions Rise Grant Program.**

**Last Amend:** 5/3/2021

**Status:** 7/14/2021-Failed Deadline pursuant to Rule 61(a)(11). (Last location was B., P. & E.D. on 6/9/2021)(May be acted upon Jan 2022)

**Is Fiscal:** Y

**Location:** 7/14/2021-S. 2 YEAR

Desk	Policy	Fiscal	Floor	Desk	2 year	Fiscal	Floor	Conf. Conc.	Enrolled	Vetoed	Chaptered
1st House				2nd House							

**Summary:** Would establish the Regions Rise Grant Program within the Office of Planning and Research for the purpose of supporting inclusive, cross-jurisdictional, and innovative engagement processes that lead to inclusive strategies to address barriers and challenges confronting communities in creating economic prosperity for all. The bill would define "region" as a geographic area composed of one or more counties and cities that form a functional economy.

**AB 215 (Chiu D) Planning and Zoning Law: housing element: violations.**

**Last Amend:** 8/16/2021

**Status:** 8/16/2021-In committee: Set, first hearing. Hearing canceled at the request of author. From committee chair, with author's amendments: Amend, and re-refer to committee. Read second time, amended, and re-referred to Com. on APPR.

**Is Fiscal:** Y

**Location:** 7/1/2021-S. APPR.

Desk	Policy	Fiscal	Floor	Desk	Policy	Fiscal	Floor	Conf. Conc.	Enrolled	Vetoed	Chaptered
1st House				2nd House							

**Summary:** The Planning and Zoning Law requires a city or county to adopt a general plan for land use development within its boundaries that includes, among other things, a housing element. That law requires a planning agency, before adopting its housing element or amendment to its housing element, to submit a draft element or draft amendment to the Department of Housing and Community Development, and requires the department to review the draft and report its written findings within 90 days of its receipt of the draft in the case of an adoption or within 60 days of its receipt in the case of a draft amendment. This bill would instead require the department to review the draft and report its written findings to the planning agency within 90 days of receiving the first draft submittal for each housing element revision or within 60 days of its receipt for a subsequent draft amendment or adoption.

**Notes:**

ACCOC - Oppose

League of California Cities - Oppose

**AB 284 (Rivas, Robert D) California Global Warming Solutions Act of 2006: climate goal: natural and working lands.**

**Last Amend:** 7/14/2021

**Status:** 8/16/2021-In committee: Referred to suspense file.

**Is Fiscal:** Y

**Location:** 8/16/2021-S. APPR. SUSPENSE FILE

Desk	Policy	Fiscal	Floor	Desk	Policy	Fiscal	Floor	Conf. Conc.	Enrolled	Vetoed	Chaptered
1st House				2nd House							

**Summary:** Would require the State Air Resources Board, as part of the next scoping plan update, in collaboration with the Natural Resources Agency and other relevant state agencies and departments and no later than January 1, 2023, to identify a 2045 climate goal, with interim milestones, for the state's natural and working lands, as defined, and to integrate into the scoping plan update recommendations developed by the Natural Resources Agency and the Department of Food and Agriculture regarding practices, policy and financial incentives, market needs, and potential reductions in barriers that would help achieve the 2045 climate goal, among other recommendations. The bill would require the state board, in collaboration with the Natural Resources Agency and other relevant state agencies and departments, to include this information in each subsequent update to the scoping plan and update that information, as appropriate.

**AB 336 (Villapudua D) Enhanced infrastructure financing districts: public financing authority: members: joint powers authorities.**

**Status:** 6/28/2021-Approved by the Governor. Chaptered by Secretary of State - Chapter 22, Statutes of 2021.

**Is Fiscal:** N

**Location:** 6/28/2021-A. CHAPTERED

Desk	Policy	Fiscal	Floor	Desk	Policy	Fiscal	Floor	Conf. Conc.	Enrolled	Vetoed	Chaptered
1st House				2nd House							

**Summary:** The Joint Exercise of Powers Act generally authorizes 2 or more public agencies, by agreement, to jointly exercise any power common to the contracting parties, as specified. Current law authorizes the agreement to set forth the manner by which the joint powers authority will be governed. This bill would specify that any member of the legislative body of a participating affected taxing entity who serves as a member of the public financing authority of an enhanced infrastructure financing district, as described above, may also serve as a member of the governing body of an agency or entity formed pursuant to an agreement for the joint exercise of power that the participating

affected taxing entity has entered into in accordance with the Joint Exercise of Powers Act.

**AB 339**

**(Lee D) Local government: open and public meetings.**

**Last Amend:** 7/5/2021

**Status:** 8/17/2021-Read second time. Ordered to third reading.

**Is Fiscal:** Y

**Location:** 8/17/2021-S. THIRD READING

Desk	Policy	Fiscal	Floor	Desk	Policy	Fiscal	Floor	Conf. Conc.	Enrolled	Vetoed	Chaptered
1st House				2nd House							

**Summary:** The Ralph M. Brown Act requires, with specified exceptions, that all meetings of a legislative body of a local agency, as those terms are defined, be open and public and that all persons be permitted to attend and participate. Under existing law, a member of the legislative body who attends a meeting where action is taken in violation of this provision, with the intent to deprive the public of information that the member knows the public is entitled to, is guilty of a crime. This bill would require local agencies to conduct meetings subject to the act consistent with applicable state and federal civil rights laws, as specified.

**Notes:** OCCCOG - Proposed Oppose Position

OCTA - Neutral

ACCOC - Oppose

League of California Cities - Oppose

Transportation Corridor Agencies - Oppose

**AB 345**

**(Quirk-Silva D) Accessory dwelling units: separate conveyance.**

**Last Amend:** 6/16/2021

**Status:** 8/17/2021-Read second time. Ordered to Consent Calendar.

**Is Fiscal:** Y

**Location:** 8/16/2021-S. CONSENT CALENDAR

Desk	Policy	Fiscal	Floor	Desk	Policy	Fiscal	Floor	Conf. Conc.	Enrolled	Vetoed	Chaptered
1st House				2nd House							

**Summary:** The Planning and Zoning Law authorizes a local agency to provide, by ordinance, for the creation of accessory dwelling units in single-family and multifamily residential zones and requires a local agency that has not adopted an ordinance to ministerially approve an application for an accessory dwelling unit, and sets forth required ordinance standards, including that the ordinance prohibit the sale or conveyance of the accessory dwelling unit separately from the primary residence. Current law, notwithstanding the prohibition described above, authorizes a local agency to, by ordinance, allow an accessory dwelling unit to be sold or conveyed separately from the primary residence to a qualified buyer if certain conditions are met. This bill would require each local agency to allow an accessory dwelling unit to be sold or conveyed separately from the primary residence to a qualified buyer if the above-described conditions are met.

**AB 361**

**(Rivas, Robert D) Open meetings: local agencies: teleconferences.**

**Last Amend:** 7/6/2021

**Status:** 7/15/2021-Read second time. Ordered to third reading.

**Is Fiscal:** N

**Location:** 7/15/2021-S. THIRD READING

Desk	Policy	Fiscal	Floor	Desk	Policy	Fiscal	Floor	Conf. Conc.	Enrolled	Vetoed	Chaptered
1st House				2nd House							

**Summary:** Existing law, the Ralph M. Brown Act requires, with specified exceptions, that all meetings of a legislative body of a local agency, as those terms are defined, be open and public and that all persons be permitted to attend and participate. This bill, until January 1, 2024, would authorize a local agency to use teleconferencing without complying with the teleconferencing requirements imposed by the Ralph M. Brown Act when a legislative body of a local agency holds a meeting during a declared state of emergency, as that term is defined, when state or local health officials have imposed or recommended measures to promote social distancing during a proclaimed state of emergency held for the purpose of determining, by majority vote, whether meeting in person would present imminent risks to the health or safety of attendees, and during a proclaimed state of emergency when the legislative body has determined that meeting in person would present imminent risks to the health or safety of attendees, as provided.

**Notes:** OCCCOG - Proposed Support Position

League of California Cities - Support

**AB 363**

**(Medina D) Carl Moyer Memorial Air Quality Standards Attainment Program.**

**Last Amend:** 7/5/2021

**Status:** 7/14/2021-Failed Deadline pursuant to Rule 61(a)(11). (Last location was TRANS. on 6/28/2021)(May be acted upon Jan 2022)

**Is Fiscal:** Y

**Location:** 7/14/2021-S. 2 YEAR

Desk	Policy	Fiscal	Floor	Desk	2 year	Fiscal	Floor	Conf. Conc.	Enrolled	Vetoed	Chaptered
1st House				2nd House							

**Summary:** Current law requires the State Air Resources Board to establish or update grant criteria and guidelines for covered vehicle and infrastructure projects as soon as practicable, but not later than July 1, 2017. The state board’s program guidelines describe the minimum criteria and requirements for on-road heavy-duty vehicles and the types of projects that can be incentivized to provide surplus emissions reductions from on-road heavy-duty vehicles through contracts or through the On-Road Heavy-Duty Voucher Incentive Program (VIP). The VIP guidelines allow for the early retirement of existing on-road heavy-duty vehicles, allowing these high-polluting vehicles to be replaced with newer, lower emission vehicles. The VIP guidelines further describe the minimum criteria and requirements for eligibility in the VIP, including, but not limited to, limiting the fleet size and vehicle weight class of eligible vehicles, excluding from program eligibility vehicles subject to the solid waste collection vehicle rule and the fleet rule for transit agencies, and prohibiting the leasing of replacement vehicles. This bill would require the state board, upon appropriation by the Legislature, to develop project grant criteria and guidelines for a new On-Road Heavy-Duty Vehicle Incentive Program (VIP2) that shall provide additional incentives for projects eligible for program funding that are deployed in disadvantaged communities, as provided, and in low-income communities, as defined.

**[AB 411](#) (Irwin D) Veterans Housing and Homeless Prevention Bond Act of 2022.**

**Last Amend:** 3/1/2021

**Status:** 5/20/2021-In committee: Hearing postponed by committee.

**Is Fiscal:** Y

**Location:** 5/5/2021-A. APPR. SUSPENSE FILE

Desk	Policy	Fiscal	Floor	Desk	Policy	Fiscal	Floor	Conf. Conc.	Enrolled	Vetoed	Chaptered
1st House				2nd House							

**Summary:** Would enact the Veterans Housing and Homeless Prevention Bond Act of 2022 to authorize the issuance of bonds in an amount not to exceed \$600,000,000 to provide additional funding for the VHHPA. The bill would provide for the handling and disposition of the funds in the same manner as the 2014 bond act.

**[AB 464](#) (Mullin D) Enhanced Infrastructure Financing Districts: allowable facilities and projects.**

**Last Amend:** 3/25/2021

**Status:** 6/28/2021-Approved by the Governor. Chaptered by Secretary of State - Chapter 25, Statutes of 2021.

**Is Fiscal:** N

**Location:** 6/28/2021-A. CHAPTERED

Desk	Policy	Fiscal	Floor	Desk	Policy	Fiscal	Floor	Conf. Conc.	Enrolled	Vetoed	Chaptered
1st House				2nd House							

**Summary:** Current law authorizes the legislative body of a city or a county to establish an enhanced infrastructure financing district to finance public capital facilities or other specified projects of communitywide significance that provide significant benefits to the district or the surrounding community, including, but not limited to, the acquisition, construction, or repair of industrial structures for private use. This bill would include, in the list of facilities and projects the district may fund, the acquisition, construction, or repair of commercial structures by the small business, as defined, occupant of such structures, if certain conditions are met, and facilities in which nonprofit community organizations provide health, youth, homeless, and social services.

**[AB 482](#) (Ward D) Housing authorities: City of San Diego, County of San Bernardino, and County of Santa Clara: middle-income housing projects pilot program.**

**Last Amend:** 3/17/2021

**Status:** 7/12/2021-Withdrawn from Engrossing and Enrolling. Held at Desk.

**Is Fiscal:** N

**Location:** 7/12/2021-A. DESK

Desk	Policy	Fiscal	Floor	Desk	Policy	Fiscal	Floor	Conf. Conc.	Enrolled	Vetoed	Chaptered
1st House				2nd House							

**Summary:** The Housing Authorities Law authorizes a housing authority of a city or county to, among other things, prepare, carry out, acquire, lease, and operate housing projects and housing developments for persons of low income, as provided. Current law, until January 1, 2022, authorizes a housing authority located in the City of San Diego, the County of San Bernardino, or the County of Santa Clara to implement a pilot program to develop and finance a middle-income housing project, as defined, if the project receives gap financing, as defined. Current law requires any gap financing to be approved by the housing authority’s legislative body, as provided. Current law requires the housing authority to provide a report to the Legislature, as specified, on and before January 1, 2020, and on or



before January 1, 2022. This bill would extend the authority of a housing authority located in the City of San Diego, the County of San Bernardino, or the County of Santa Clara to implement the above-described pilot program from January 1, 2022, to January 1, 2026.

**[AB 500](#) (Ward D) Local planning: coastal development: affordable housing.**

**Last Amend:** 7/13/2021

**Status:** 8/16/2021-In committee: Referred to suspense file.

**Is Fiscal:** Y

**Location:** 8/16/2021-S. APPR. SUSPENSE FILE

Desk	Policy	Fiscal	Floor	Desk	Policy	Fiscal	Floor	Conf. Conc.	Enrolled	Vetoed	Chaptered
1st House				2nd House							

**Summary:** Would require the California Coastal Commission to conduct and complete a study on or before January 1, 2023, that identifies recommendations for policy changes that advance affordable housing in the coastal zone. The bill would provide that the study may include recommendations regarding the commission’s authority related to the development of lower income housing and recommendations regarding streamlining of local government and commission review of affordable housing projects.

**Notes:**

League of California Cities - Oppose

**[AB 571](#) (Mayes I) Planning and zoning: density bonuses: affordable housing.**

**Last Amend:** 5/3/2021

**Status:** 8/16/2021-Read second time. Ordered to third reading.

**Is Fiscal:** Y

**Location:** 8/16/2021-S. THIRD READING

Desk	Policy	Fiscal	Floor	Desk	Policy	Fiscal	Floor	Conf. Conc.	Enrolled	Vetoed	Chaptered
1st House				2nd House							

**Summary:** The Density Bonus Law requires a city or county to provide a developer that proposes a housing development in the city or county with a density bonus and other incentives or concessions for the production of lower income housing units, or for the donation of land within the development, if the developer agrees to, among other things, construct a specified percentage of units for very low income, low-income, or moderate-income households or qualifying residents, including lower income students. Current law requires the amount of a density bonus and the number of incentives or concessions a qualifying developer receives to be pursuant to a certain formula based on the total number of units in the housing development, as specified. This bill would prohibit affordable housing impact fees, including inclusionary zoning fees and in-lieu fees, from being imposed on a housing development’s affordable units.

**Notes:**

BIA - Support

**[AB 585](#) (Rivas, Luz D) Climate change: Extreme Heat and Community Resilience Program.**

**Last Amend:** 7/13/2021

**Status:** 8/16/2021-In committee: Referred to suspense file.

**Is Fiscal:** Y

**Location:** 8/16/2021-S. APPR. SUSPENSE FILE

Desk	Policy	Fiscal	Floor	Desk	Policy	Fiscal	Floor	Conf. Conc.	Enrolled	Vetoed	Chaptered
1st House				2nd House							

**Summary:** Would establish the Extreme Heat and Community Resilience Program for the purpose of coordinating state efforts and supporting local and regional efforts to mitigate the impacts of, and reduce the public health risks of, extreme heat and the urban heat island effect, and would require the Office of Planning and Research to administer the program through the Integrated Climate Adaptation and Resiliency Program.

**Notes:**

League of California Cities - Support

**[AB 602](#) (Grayson D) Development fees: impact fee nexus study.**

**Last Amend:** 7/5/2021

**Status:** 8/16/2021-In committee: Referred to suspense file.

**Is Fiscal:** Y

**Location:** 8/16/2021-S. APPR. SUSPENSE FILE

Desk	Policy	Fiscal	Floor	Desk	Policy	Fiscal	Floor	Conf. Conc.	Enrolled	Vetoed	Chaptered
1st House				2nd House							

**Summary:** Current law requires a city, county, or special district that has an internet website to make available on its internet website certain information, as applicable, including its current schedule of

fees and exactions. This bill, among other things, would require, on and after January 1, 2022, a city, county, or special district that conducts an impact fee nexus study to follow specific standards and practices, including, but not limited to, (1) that prior to the adoption of an associated development fee, an impact fee nexus study be adopted, (2) that the study identify the existing level of service for each public facility, identify the proposed new level of service, and include an explanation of why the new level of service is necessary, and (3) if the study is adopted after July 1, 2022, either calculate a fee levied or imposed on a housing development project proportionately to the square footage of the proposed units, or make specified findings explaining why square footage is not an appropriate metric to calculate the fees.

**Notes:**

BIA - Support  
League of California Cities - Oppose Unless Amended

**AB 604 (Daly D) Road Maintenance and Rehabilitation Account: apportionment of funds: accrued interest.**

**Status:** 7/15/2021-In committee: Referred to suspense file.

**Is Fiscal:** Y

**Location:** 7/15/2021-S. APPR. SUSPENSE FILE

Desk	Policy	Fiscal	Floor	Desk	Policy	Fiscal	Floor	Conf. Conc.	Enrolled	Vetoed	Chaptered
1st House				2nd House							

**Summary:** Would continuously appropriate interest earnings derived from revenues deposited in the Road Maintenance and Rehabilitation Account to the Department of Transportation for maintenance of the state highway system or for purposes of the State Highway Operation and Protection Program.

**AB 617 (Davies R) Planning and zoning: regional housing needs: exchange of allocation.**

**Status:** 5/7/2021-Failed Deadline pursuant to Rule 61(a)(3). (Last location was H. & C.D. on 2/25/2021)(May be acted upon Jan 2021)

**Is Fiscal:** N

**Location:** 5/7/2021-A. 2 YEAR

Desk	2 year	Fiscal	Floor	Desk	Policy	Fiscal	Floor	Conf. Conc.	Enrolled	Vetoed	Chaptered
1st House				2nd House							

**Summary:** Would authorize a city or county, by agreement, to transfer all or a portion of its allocation of regional housing need to another city or county. The bill would allow the transferring city to pay the transferee city or county an amount determined by that agreement, as well as a surcharge to offset the impacts and associated costs of the additional housing on the transferee city. The bill would also require the transferring city or county and the transferee city or county to report to the council of governments and the department specified information about the transfer, as provided.

**Notes:**

OCCOG - Support  
ACCOC - Support

**AB 634 (Carrillo D) Density Bonus Law.**

**Last Amend:** 4/20/2021

**Status:** 6/21/2021-Read second time. Ordered to third reading.

**Is Fiscal:** N

**Location:** 6/21/2021-S. THIRD READING

Desk	Policy	Fiscal	Floor	Desk	Policy	Fiscal	Floor	Conf. Conc.	Enrolled	Vetoed	Chaptered
1st House				2nd House							

**Summary:** The Density Bonus Law, requires a city or county to provide a developer that proposes a housing development within the city or county with a density bonus and other incentives or concessions, as specified, if the developer agrees to construct specified percentages of units for lower income, very low income, or senior citizen housing, among other things, and meets other requirements. Current law prescribes an application process for a city or county to follow in this regard. Current law specifies that, if permitted by local ordinance, that law is not to be construed to prohibit a city, county, or city and county from granting a density bonus greater than what is described in these provisions for a development that meets specified requirements or from granting a proportionately lower density bonus than what is required for developments that do not meet these requirements. This bill would also provide that, if permitted by local ordinance, the Density Bonus Law is not to be construed to prohibit a city, county, or city and county from requiring an affordability period that is longer than 55 years for any units that qualified the applicant for the award for the density bonus developed in compliance with a local ordinance that requires, as a condition of development of residential units, that a development include a certain percentage of units that are affordable to, and occupied by low-income, lower income, very low income, or extremely low income households and that will be financed without low-income housing tax credits.

**AB 672 (Garcia, Cristina D) Planning and zoning law: rezoning authorization: golf courses.**

**Last Amend:** 4/6/2021

**Status:** 4/30/2021-Failed Deadline pursuant to Rule 61(a)(2). (Last location was H. & C.D. on 3/18/2021)(May be acted upon Jan 2022)

**Is Fiscal:** Y

**Location:** 4/30/2021-A. 2 YEAR

Desk	2 year	Fiscal	Floor	Desk	Policy	Fiscal	Floor	Conf. Conc.	Enrolled	Vetoed	Chaptered
1st House				2nd House							

**Summary:** Would require a city, county, or city and county to rezone, by the date the 6th regional housing needs assessment cycle applicable to the city, county, or city and county ends, certain sites used as a golf course to also allow for residential and open-space use in accordance with specified requirements. The bill would exempt any ordinance, resolution, general or specific plan amendment, or other action necessary of the city, county, or city and county to rezone a site pursuant to the bill's provisions from CEQA. The bill would require a development on a site that is rezoned for residential and open-space use pursuant to the bill's provisions to comply with specified requirements, including that 25 percent of all units developed on the site be available for persons and families of low income for a period of at least 45 years for owner-occupied units and at least 55 years for rental units, and that a certain unit per acre density be met.

**Notes:** OCCOG - Proposed Oppose Position

**AB 687 (Sevarto R) Joint powers authorities: Riverside County Housing Finance Trust.**

**Status:** 7/23/2021-Approved by the Governor. Chaptered by Secretary of State - Chapter 120, Statutes of 2021.

**Is Fiscal:** N

**Location:** 7/23/2021-A. CHAPTERED

Desk	Policy	Fiscal	Floor	Desk	Policy	Fiscal	Floor	Conf. Conc.	Enrolled	Vetoed	Chaptered
1st House				2nd House							

**Summary:** Would authorize the creation of the Western Riverside County Housing Finance Trust, a joint powers authority, for the purposes of funding housing specifically assisting the homeless population and persons and families of extremely low, very low, and low income within the County of Riverside as specified.

**Notes:**

OCCOG - Support

SCAG - Support

**AB 713 (Garcia, Cristina D) State Air Resources Board: greenhouse gas emissions scoping plan: comprehensive health analysis.**

**Last Amend:** 5/24/2021

**Status:** 7/15/2021-In committee: Referred to suspense file.

**Is Fiscal:** Y

**Location:** 7/15/2021-S. APPR. SUSPENSE FILE

Desk	Policy	Fiscal	Floor	Desk	Policy	Fiscal	Floor	Conf. Conc.	Enrolled	Vetoed	Chaptered
1st House				2nd House							

**Summary:** The State Air Resources Board as the state agency charged with monitoring and regulating sources of emissions of greenhouse gases. The state board is required to approve a statewide greenhouse gas emissions limit equivalent to the statewide greenhouse gas emissions level in 1990 to be achieved by 2020 and to ensure that statewide greenhouse gas emissions are reduced to at least 40% below the 1990 level by 2030. The act requires the state board to prepare and approve a scoping plan for achieving the maximum technologically feasible and cost-effective reductions in greenhouse This bill would require the state board to conduct a comprehensive health analysis in conjunction with the development of each update of the scoping plan that includes a framework to provide an overview of the breadth of health impacts and health benefits that may accrue from the outcomes in the scoping plan, as specified.

**AB 787 (Gabriel D) Planning and zoning: housing element: converted affordable housing units.**

**Last Amend:** 5/3/2021

**Status:** 8/16/2021-In committee: Referred to suspense file.

**Is Fiscal:** Y

**Location:** 8/16/2021-S. APPR. SUSPENSE FILE

Desk	Policy	Fiscal	Floor	Desk	Policy	Fiscal	Floor	Conf. Conc.	Enrolled	Vetoed	Chaptered
1st House				2nd House							

**Summary:** Current law requires the planning agency of a city or county to provide an annual report that includes specified information by April 1 of each year to specified entities, including the Department of Housing and Community Development. Among other things, existing law requires that this report include the progress in meeting the city's or county's share of regional housing needs and local efforts to remove governmental constraints to the maintenance, improvement, and development

of housing, as specified. This bill would authorize a planning agency to include in its annual report the number of units in an existing multifamily building that were converted to deed-restricted rental housing for very low, low-, or moderate-income households by the imposition of affordability covenants and restrictions for the unit.

**Notes:**

OCCOG - Support  
ACCOC - Support

**AB 816 (Chiu D) Homelessness: Housing Trust Fund: housing projects.**

**Last Amend:** 7/16/2021

**Status:** 8/16/2021-In committee: Hearing postponed by committee.

**Is Fiscal:** Y

**Location:** 7/7/2021-S. APPR.

Desk	Policy	Fiscal	Floor	Desk	Policy	Fiscal	Floor	Conf. Conc.	Enrolled	Vetoed	Chaptered
1st House				2nd House							

**Summary:** Current federal law requires the Secretary of the United States Department of Housing and Urban Development to establish a Housing Trust Fund to provide grants to states to increase the supply of rental housing for extremely low and very low income families, including homeless families, and home ownership for extremely low and very low income families. Current law requires the department to collaborate with the California Housing Finance Agency to develop an allocation plan to demonstrate how the funds will be distributed, based on the priority housing needs identified in the state's consolidated plan, and to convene a stakeholder process to inform the development of the plan. Current law requires the allocation plan and program guidelines to prioritize projects based on enumerated factors such as the extent to which project rents are affordable. The department is required to submit this plan to the Assembly Committee on Housing and Community Development and the Senate Transportation and Housing Committees 30 days after receipt of the federal funds. This bill would require the department to prioritize funding for projects that serve people experiencing homelessness, to the extent that a sufficient number of projects exist.

**Notes:** OCCOG - Oppose

League of California Cities - Oppose

**AB 897 (Mullin D) Office of Planning and Research: regional climate networks: regional climate adaptation and resilience action plans.**

**Last Amend:** 7/14/2021

**Status:** 8/16/2021-In committee: Referred to suspense file.

**Is Fiscal:** Y

**Location:** 8/16/2021-S. APPR. SUSPENSE FILE

Desk	Policy	Fiscal	Floor	Desk	Policy	Fiscal	Floor	Conf. Conc.	Enrolled	Vetoed	Chaptered
1st House				2nd House							

**Summary:** Current law requires, by July 1, 2017, and every 3 years thereafter, the Natural Resources Agency to update, as prescribed, the state's climate adaptation strategy, known as the Safeguarding California Plan. Current law establishes the Office of Planning and Research in state government in the Governor's office. Current law establishes the Integrated Climate Adaptation and Resiliency Program to be administered by the office to coordinate regional and local efforts with state climate adaptation strategies to adapt to the impacts of climate change, as prescribed. This bill would authorize eligible entities, as defined, to establish and participate in a regional climate network, as defined. The bill would require the office, through the program, to encourage the inclusion of eligible entities with land use planning and hazard mitigation planning authority into regional climate networks. The bill would authorize a regional climate network to engage in activities to address climate change, as specified.

**Notes:**

League of California Cities - Support

**AB 950 (Ward D) Department of Transportation: sales of excess real property: affordable housing, emergency shelters, and feeding programs.**

**Last Amend:** 7/13/2021

**Status:** 8/16/2021-In committee: Set, first hearing. Hearing canceled at the request of author.

**Is Fiscal:** Y

**Location:** 7/12/2021-S. APPR.

Desk	Policy	Fiscal	Floor	Desk	Policy	Fiscal	Floor	Conf. Conc.	Enrolled	Vetoed	Chaptered
1st House				2nd House							

**Summary:** Would authorize the Department of Transportation to sell its excess real property to the city, county, or city and county where the real property is located if the city, county, or city and county agrees to use the real property for the sole purpose of implementing affordable housing, emergency shelters, or feeding programs, as specified. The bill would exempt these sales from the California Environmental Quality Act, except the department would be required to file a notice of exemption with

the Office of Planning and Research and the county clerk of the county in which the real property is located.

**[AB 970](#) (McCarty D) Planning and zoning: electric vehicle charging stations: permit application: approval.**

**Last Amend:** 7/13/2021

**Status:** 7/13/2021-Read second time and amended. Ordered to third reading.

**Is Fiscal:** N

**Location:** 7/13/2021-S. THIRD READING

Desk	Policy	Fiscal	Floor	Desk	Policy	Fiscal	Floor	Conf. Conc.	Enrolled	Vetoed	Chaptered
1st House				2nd House							

**Summary:** Current law requires every city, county, and city and county to create an expedited, streamlined permitting process for electric vehicle charging stations and to adopt a checklist pursuant to which an applicant that satisfies the information requirements shall be deemed complete and therefore eligible for expedited review. This bill would clarify that these provisions apply to all cities, including charter cities.

**Notes:**

League of California Cities - Oppose

**[AB 977](#) (Gabriel D) Homelessness program data reporting: Homeless Management Information System.**

**Last Amend:** 7/12/2021

**Status:** 8/16/2021-In committee: Referred to suspense file.

**Is Fiscal:** Y

**Location:** 8/16/2021-S. APPR. SUSPENSE FILE

Desk	Policy	Fiscal	Floor	Desk	Policy	Fiscal	Floor	Conf. Conc.	Enrolled	Vetoed	Chaptered
1st House				2nd House							

**Summary:** Would require, on or before January 1, 2023, that a grantee or entity operating specified state homelessness programs, including the No Place Like Home Program, as a condition of receiving state funds, to enter the collected data elements on the individuals and families it serves into its local Homeless Management Information System, unless otherwise exempted by state or federal law. The bill would require the Homeless Coordinating and Financing Council to specify the format and disclosure frequency of the required data elements. The bill would apply the data entry requirements to all new state homelessness programs that commence on or after July 1, 2021. The bill would require the Homeless Coordinating and Financing Council to provide technical assistance to any grantee or entity that operates a program subject to the bill, if the grantee or entity does not already collect and enter into the local Homeless Management Information System the data elements required.

**[AB 989](#) (Gabriel D) Housing Accountability Act: appeals: Office of Housing Appeals.**

**Last Amend:** 8/18/2021

**Status:** 8/18/2021-From committee chair, with author's amendments: Amend, and re-refer to committee. Read second time, amended, and re-referred to Com. on APPR.

**Is Fiscal:** Y

**Location:** 7/8/2021-S. APPR.

Desk	Policy	Fiscal	Floor	Desk	Policy	Fiscal	Floor	Conf. Conc.	Enrolled	Vetoed	Chaptered
1st House				2nd House							

**Summary:** The Housing Accountability Act prohibits a local agency from disapproving, or conditioning approval in a manner that renders infeasible, specified housing development projects, including projects for very low, low-, or moderate-income households and projects for emergency shelters that comply with applicable, objective general plan, zoning, and subdivision standards and criteria in effect at the time the application for the project is deemed complete, unless the local agency makes specified written findings based on a preponderance of the evidence in the record. This bill would, until January 1, 2029, establish an Office of Housing Appeals (office) within the department, administered by the director of the department, to review housing development projects that are alleged to have been denied or subject to conditions in violation of the Housing Accountability Act. The bill would establish housing appeals panels, consisting of administrative law judges with specified qualifications, within the office.

**Notes:** OCCOG - Proposed Oppose Position

League of California Cities - Oppose

**[AB 1029](#) (Mullin D) Housing elements: prohousing local policies.**

**Last Amend:** 7/9/2021

**Status:** 8/16/2021-Read second time. Ordered to third reading.

**Is Fiscal:** Y

**Location:** 8/16/2021-S. THIRD READING

Desk	Policy	Fiscal	Floor	Desk	Policy	Fiscal	<b>Floor</b>	Conf. Conc.	Enrolled	Vetoed	Chaptered
1st House				2nd House							

**Summary:** Would add the preservation of affordable housing units through the extension of existing project-based rental assistance covenants to avoid the displacement of affected tenants and a reduction in available affordable housing units to the list of specified prohousing local policies.

**[AB 1035](#) (Salas D) Department of Transportation and local agencies: streets and highways: recycled materials.**

**Last Amend:** 6/28/2021

**Status:** 7/15/2021-In committee: Referred to suspense file.

**Is Fiscal:** Y

**Location:** 7/15/2021-S. APPR. SUSPENSE FILE

Desk	Policy	Fiscal	Floor	Desk	Policy	<b>Fiscal</b>	Floor	Conf. Conc.	Enrolled	Vetoed	Chaptered
1st House				2nd House							

**Summary:** Would require the Department of Transportation and a local agency that has jurisdiction over a street or highway, to the extent feasible and cost effective, to use advanced technologies and material recycling techniques that reduce the cost of maintaining and rehabilitating streets and highways and that exhibit reduced levels of greenhouse gas emissions through material choice and construction method. The bill would require, beginning January 1, 2023, a local agency that has jurisdiction over a street or highway, to the extent feasible and cost effective, to apply standard specifications that allow for the use of recycled materials in streets and highways, as specified. By increasing the duties of local agencies, this bill would impose a state-mandated local program.

**Notes:**

League of California Cities - Oppose Unless Amended

**[AB 1049](#) (Davies R) Public Transportation Account: loan repayment.**

**Status:** 3/4/2021-Referred to Com. on TRANS.

**Is Fiscal:** Y

**Location:** 3/4/2021-A. TRANS.

Desk	<b>Policy</b>	Fiscal	Floor	Desk	Policy	Fiscal	Floor	Conf. Conc.	Enrolled	Vetoed	Chaptered
1st House				2nd House							

**Summary:** Current law requires the transfer of a specified portion of the sales tax on diesel fuel to the Public Transportation Account, a trust fund in the State Transportation Fund. Current law requires funds in the account to be allocated to various public transportation and transportation planning purposes, with specified revenues in the account to be allocated by the Controller to specified local transportation agencies for public transportation purposes, pursuant to the State Transit Assistance (STA) Program. Current law provides for each STA-eligible operator within the jurisdiction of the allocating local transportation agency to receive a proportional share of the revenue-based program funds based on the qualifying revenues of that operator, as defined. The Budget Act of 2013 and the Budget Act of 2014 require the Controller, upon the order of the Director of Finance, to transfer specified amounts totaling up to \$55,515,000 as loans from the Public Transportation Account to the High-Speed Passenger Train Bond Fund. This bill would require \$54,000,000 from these loans to be repaid to the Public Transportation Account and would provide that these repaid funds are available, upon appropriation by the Legislature, to help offset the loss of revenues incurred by transit operators during the COVID-19 pandemic.

**[AB 1147](#) (Friedman D) Regional transportation plan: Active Transportation Program.**

**Last Amend:** 8/16/2021

**Status:** 8/16/2021-From committee chair, with author's amendments: Amend, and re-refer to committee. Read second time, amended, and re-referred to Com. on APPR.

**Is Fiscal:** Y

**Location:** 7/13/2021-S. APPR.

Desk	Policy	Fiscal	Floor	Desk	Policy	<b>Fiscal</b>	Floor	Conf. Conc.	Enrolled	Vetoed	Chaptered
1st House				2nd House							

**Summary:** Current law requires the Strategic Growth Council, by January 31, 2022, to complete an overview of the California Transportation Plan and all sustainable communities strategies and alternative planning strategies, an assessment of how implementation of the California Transportation Plan, sustainable communities strategies, and alternative planning strategies will influence the configuration of the statewide integrated multimodal transportation system, and a review of the potential impacts and opportunities for coordination of specified funding programs. This bill would require the council to convene key state agencies, metropolitan planning agencies, regional transportation agencies, and local governments to assist the council in completing the report.

**[AB 1220](#) (Rivas, Luz D) Homelessness: California Interagency Council on Homelessness.**

**Last Amend:** 6/24/2021

**Status:** 8/17/2021-Read second time. Ordered to third reading.

**Is Fiscal:** Y

**Location:** 8/17/2021-S. THIRD READING

Desk	Policy	Fiscal	Floor	Desk	Policy	Fiscal	Floor	Conf. Conc.	Enrolled	Vetoed	Chaptered
1st House				2nd House							

**Summary:** Would rename the Homeless Coordinating and Financing Council to the California Interagency Council on Homelessness and remove authorization for the Secretary of Business, Consumer Services and Housing's designee to serve as chair of the council. The bill would also change the composition of the council, as specified, including by creating and specifying the membership of an advisory committee to the council. The bill would also provide that the appointed members of the council or committees serve at the pleasure of their appointing authority. The bill would also require that upon request of the council, a state agency or department that administers one or more state homelessness programs, as described, to participate in council workgroups, task forces, or other similar administrative structures and to provide to the council any relevant information regarding those state homelessness programs.

**AB 1258 (Nguyen R) Housing element: regional housing need plan: judicial review.**

**Last Amend:** 3/22/2021

**Status:** 4/30/2021-Failed Deadline pursuant to Rule 61(a)(2). (Last location was H. & C.D. on 3/4/2021)(May be acted upon Jan 2022)

**Is Fiscal:** Y

**Location:** 4/30/2021-A. 2 YEAR

Desk	2 year	Fiscal	Floor	Desk	Policy	Fiscal	Floor	Conf. Conc.	Enrolled	Vetoed	Chaptered
1st House				2nd House							

**Summary:** Under current law the Department of Housing and Community Development, in consultation with each council of governments, determines each region's existing and projected housing needs. Under existing law, upon making that determination, the council of governments may object to the determination, and the department is required to respond to an objection by making a final written determination. Current law requires that, based on the determination of the department, a council of governments, or for cities and counties without a council of governments, the department, adopts a final regional housing need plan that allocates a share of the regional housing need to each locality in the region. This bill would subject the department's final written determination of a region's housing needs to judicial review in an action brought by the council of governments. The bill would also subject the final regional housing need plan adopted by the council of governments or the department, as the case may be, to judicial review.

**Notes:**

OCCOG - Support

ACCOC - Support

**AB 1260 (Chen R) California Environmental Quality Act: exemptions: transportation-related projects.**

**Last Amend:** 7/6/2021

**Status:** 8/16/2021-In committee: Referred to suspense file.

**Is Fiscal:** Y

**Location:** 8/16/2021-S. APPR. SUSPENSE FILE

Desk	Policy	Fiscal	Floor	Desk	Policy	Fiscal	Floor	Conf. Conc.	Enrolled	Vetoed	Chaptered
1st House				2nd House							

**Summary:** CEQA includes exemptions from its environmental review requirements for numerous categories of projects, including, among others, projects for the institution or increase of passenger or commuter services on rail or highway rights-of-way already in use and projects by a public transit agency to construct or maintain infrastructure to charge or refuel zero-emission transit buses. This bill would further exempt from the requirements of CEQA projects by a public transit agency to construct or maintain infrastructure to charge or refuel zero-emission trains, provided certain requirements are met, including giving prior notice to the public and holding a noticed public meeting, as provided.

**AB 1322 (Rivas, Robert D) California Global Warming Solutions Act of 2006: scoping plan: sustainable aviation fuels.**

**Last Amend:** 6/21/2021

**Status:** 7/14/2021-Failed Deadline pursuant to Rule 61(a)(11). (Last location was E.Q. on 6/24/2021) (May be acted upon Jan 2022)

**Is Fiscal:** Y

**Location:** 7/14/2021-S. 2 YEAR

Desk	Policy	Fiscal	Floor	Desk	2 year	Fiscal	Floor	Conf. Conc.	Enrolled	Vetoed	Chaptered
1st House				2nd House							

**Summary:** Would require the State Air Resources Board, as part of the next scoping plan update, to develop a plan, consistent with federal law, to use sustainable aviation fuels to reduce greenhouse

gas emissions from aircrafts in the state by 40% below 1990 levels by 2030 and to achieve net-zero greenhouse gas emissions by 2045. The bill would require, no later than January 1, 2023, the state board to undertake certain actions, including consulting with designated state agencies and, if feasible, commercial airports, commercial and business airlines that operate in the state, aircraft manufacturers, sustainable aviation fuels producers and developers, and infrastructure providers to develop the plan.

**[AB 1384](#) (Gabriel D) Resiliency Through Adaptation, Economic Vitality, and Equity Act of 2022.**

**Last Amend:** 7/14/2021

**Status:** 8/16/2021-In committee: Referred to suspense file.

**Is Fiscal:** Y

**Location:** 8/16/2021-S. APPR. SUSPENSE FILE

Desk	Policy	Fiscal	Floor	Desk	Policy	Fiscal	Floor	Conf. Conc.	Enrolled	Vetoed	Chaptered
1st House				2nd House							

**Summary:** Current law requires the Natural Resources Agency to update every 3 years the state's climate adaptation strategy, known as the Safeguarding California Plan, and to coordinate with other state agencies to identify vulnerabilities to climate change by sectors and priority actions needed to reduce the risks in those sectors. Current law requires, to address the vulnerabilities identified in the plan, state agencies to maximize specified objectives. This bill would require the agency to also coordinate with the Office of Planning and Research and identify, among other things, vulnerabilities to climate change for vulnerable communities, an operational definition of "climate resilience" for each sector and for vulnerable communities, special protections of vulnerable communities and industries that are disproportionately impacted by climate change, and timetables and specific metrics to measure the state's progress in implementing the plan.

**[AB 1395](#) (Muratsuchi D) The California Climate Crisis Act.**

**Last Amend:** 7/13/2021

**Status:** 8/16/2021-In committee: Referred to suspense file.

**Is Fiscal:** Y

**Location:** 8/16/2021-S. APPR. SUSPENSE FILE

Desk	Policy	Fiscal	Floor	Desk	Policy	Fiscal	Floor	Conf. Conc.	Enrolled	Vetoed	Chaptered
1st House				2nd House							

**Summary:** The California Global Warming Solutions Act of 2006 requires the State Air Resources Board to prepare and approve a scoping plan for achieving the maximum technologically feasible and cost-effective reductions in greenhouse gas emissions and to update the scoping plan at least once every 5 years. This bill, the California Climate Crisis Act, would declare the policy of the state both to achieve net zero greenhouse gas emissions as soon as possible, but no later than 2045, and achieve and maintain net negative greenhouse gas emissions thereafter, and to ensure that by 2045, statewide anthropogenic greenhouse gas emissions are reduced to at least 90% below the 1990 levels.

**[AB 1401](#) (Friedman D) Residential and commercial development: remodeling, renovations, and additions: parking requirements.**

**Last Amend:** 7/5/2021

**Status:** 8/16/2021-In committee: Referred to suspense file.

**Is Fiscal:** Y

**Location:** 8/16/2021-S. APPR. SUSPENSE FILE

Desk	Policy	Fiscal	Floor	Desk	Policy	Fiscal	Floor	Conf. Conc.	Enrolled	Vetoed	Chaptered
1st House				2nd House							

**Summary:** Would prohibit a public agency in a county with a population of 600,000 or more from imposing a minimum automobile parking requirement, or enforcing a minimum automobile parking requirement, on residential, commercial, or other development if the development is located on a parcel that is within 1/2 mile, as specified, of public transit, as defined. The bill would prohibit a public agency in a city with of 75,000 or more located in a county with a population of less than 600,000 from imposing a minimum automobile parking requirement, or enforcing a minimum automobile parking requirement, on residential, commercial, or other development if the project is located within 1/4 mile, as specified, of public transit, as defined. The bill would create authorizations in this regard for a city or a county to which these prohibitions do not apply.

**Notes:** League of California Cities - Oppose

**[AB 1499](#) (Daly D) Transportation: design-build: highways.**

**Last Amend:** 5/24/2021

**Status:** 8/16/2021-Read second time. Ordered to third reading.

**Is Fiscal:** Y

**Location:** 8/16/2021-S. THIRD READING



Desk	Policy	Fiscal	Floor	Desk	Policy	Fiscal	Floor	Conf. Conc.	Enrolled	Vetoed	Chaptered
1st House				2nd House							

**Summary:** Current law authorizes regional transportation agencies, as defined, to utilize design-build procurement for projects on or adjacent to the state highway system. Current law also authorizes those regional transportation agencies to utilize design-build procurement for projects on expressways that are not on the state highway system, as specified. Current law repeals these provisions on January 1, 2024, or one year from the date that the Department of Transportation posts on its internet website that the provisions described below related to construction inspection services for these projects have been held by a court to be invalid. This bill would extend the operation of these provisions until January 1, 2034. The bill would require the department to submit a report to specified committees of the Legislature on or before January 1, 2033, on its experience with design-build procurement.

**Notes:**

OCTA - Support

**ACA 1**

**(Aguiar-Curry D) Local government financing: affordable housing and public infrastructure: voter approval.**

**Status:** 4/22/2021-Referred to Coms. on L. GOV. and APPR.

**Is Fiscal:** N

**Location:** 4/22/2021-A. L. GOV.

Desk	Policy	Fiscal	Floor	Desk	Policy	Fiscal	Floor	Conf. Conc.	Enrolled	Vetoed	Chaptered
1st House				2nd House							

**Summary:** The California Constitution prohibits the ad valorem tax rate on real property from exceeding 1% of the full cash value of the property, subject to certain exceptions. This measure would create an additional exception to the 1% limit that would authorize a city, county, city and county, or special district to levy an ad valorem tax to service bonded indebtedness incurred to fund the construction, reconstruction, rehabilitation, or replacement of public infrastructure, affordable housing, or permanent supportive housing, or the acquisition or lease of real property for those purposes, if the proposition proposing that tax is approved by 55% of the voters of the city, county, or city and county, as applicable, and the proposition includes specified accountability requirements.

**Notes:**

ACCOC - Watch

SCAG - Support

OCBC - Oppose

**SB 1**

**(Atkins D) Coastal resources: sea level rise.**

**Last Amend:** 6/24/2021

**Status:** 7/14/2021-July 14 set for first hearing. Placed on suspense file.

**Is Fiscal:** Y

**Location:** 7/14/2021-A. APPR. SUSPENSE FILE

Desk	Policy	Fiscal	Floor	Desk	Policy	Fiscal	Floor	Conf. Conc.	Enrolled	Vetoed	Chaptered
1st House				2nd House							

**Summary:** The California Coastal Act of 1976 establishes the California Coastal Commission and provides for planning and regulation of development in the coastal zone, as defined. The act requires the commission, within 90 days after January 1, 1977, to adopt, after public hearing, procedures for the preparation, submission, approval, appeal, certification, and amendment of a local coastal program, including a common methodology for the preparation of, and the determination of the scope of, the local coastal programs, as provided. This bill would also include, as part of the procedures the commission is required to adopt, recommendations and guidelines for the identification, assessment, minimization, and mitigation of sea level rise within each local coastal program, as provided. The bill would delete the timeframe specified above by which the commission is required to adopt these procedures.

**Notes:**

ACCOC - Watch

OCBC - Watch

League of California Cities - Support

**SB 5**

**(Atkins D) Affordable Housing Bond Act of 2022.**

**Last Amend:** 3/10/2021

**Status:** 3/18/2021-Re-referred to Coms. on HOUSING and GOV. & F.

**Is Fiscal:** Y

**Location:** 3/18/2021-S. HOUSING

Desk	Policy	Fiscal	Floor	Desk	Policy	Fiscal	Floor	Conf. Conc.	Enrolled	Vetoed	Chaptered
1st House				2nd House							

**Summary:** Would enact the Affordable Housing Bond Act of 2022, which, if adopted, would authorize

the issuance of bonds in the amount of \$6,500,000,000 pursuant to the State General Obligation Bond Law. Proceeds from the sale of these bonds would be used to fund affordable rental housing and homeownership programs. The bill would state the intent of the Legislature to determine the allocation of those funds to specific programs. This bill would provide for submission of the bond act to the voters at the November 8, 2022, statewide general election in accordance with specified law.

**Notes:** OCCOG - Watch  
 ACCOC - Watch  
 SCAG - Support

**SB 6**

**(Caballero D) Local planning: housing: commercial zones.**

**Last Amend:** 4/12/2021

**Status:** 7/14/2021-Failed Deadline pursuant to Rule 61(a)(11). (Last location was DESK on 5/24/2021) (May be acted upon Jan 2022)

**Is Fiscal:** Y

**Location:** 7/14/2021-A. 2 YEAR

Desk	Policy	Fiscal	Floor	2 year	Policy	Fiscal	Floor	Conf. Conc.	Enrolled	Vetoed	Chaptered
1st House				2nd House							

**Summary:** The Planning and Zoning Law requires each county and city to adopt a comprehensive, long-term general plan for its physical development, and the development of certain lands outside its boundaries, that includes, among other mandatory elements, a housing element. This bill, the Neighborhood Homes Act, would deem a housing development project, as defined, an allowable use on a neighborhood lot, which is defined as a parcel within an office or retail commercial zone that is not adjacent to an industrial use. The bill would require the density for a housing development under these provisions to meet or exceed the density deemed appropriate to accommodate housing for lower income households according to the type of local jurisdiction, including a density of at least 20 units per acre for a suburban jurisdiction.

**Notes:** OCCOG - Oppose  
 ACCOC - Oppose  
 OCBC - Support If Amended  
 SCAG - Watch

**SB 7**

**(Atkins D) Environmental quality: Jobs and Economic Improvement Through Environmental Leadership Act of 2021.**

**Last Amend:** 2/18/2021

**Status:** 5/20/2021-Approved by the Governor. Chaptered by Secretary of State. Chapter 19, Statutes of 2021.

**Is Fiscal:** Y

**Location:** 5/20/2021-S. CHAPTERED

Desk	Policy	Fiscal	Floor	Desk	Policy	Fiscal	Floor	Conf. Conc.	Enrolled	Vetoed	Chaptered
1st House				2nd House							

**Summary:** Would enact the Jobs and Economic Improvement Through Environmental Leadership Act of 2021, which would reenact the former leadership act, with certain changes, and would authorize the Governor, until January 1, 2024, to certify projects that meet specified requirements for streamlining benefits related to CEQA. The bill would additionally include housing development projects, as defined, meeting certain conditions as projects eligible for certification. The bill would, except for those housing development projects, require the quantification and mitigation of the impacts of a project from the emissions of greenhouse gases, as provided. The bill would revise and recast the labor-related requirements for projects undertaken by both public agencies and private entities. The bill would provide that the Governor is authorized to certify a project before the lead agency certifies the final EIR for the project.

**Notes:**  
 OCCOG - Support  
 SCAG - Support  
 ACCOC - Watch

**SB 8**

**(Skinner D) Housing Crisis Act of 2019.**

**Last Amend:** 7/5/2021

**Status:** 8/19/2021-From committee: Do pass. (Ayes 16. Noes 0.) (August 19).

**Is Fiscal:** Y

**Location:** 7/1/2021-A. APPR.

Desk	Policy	Fiscal	Floor	Desk	Policy	Fiscal	Floor	Conf. Conc.	Enrolled	Vetoed	Chaptered
1st House				2nd House							

**Summary:** Would clarify, for various purposes of the Housing Crisis Act of 2019, that "housing development project" includes projects that involve no discretionary approvals, projects that involve both discretionary and nondiscretionary approvals, and projects that include a proposal to construct a

single dwelling unit. The bill would specify that this clarification is declaratory of existing law.

**Notes:**

OCCOG - Watch  
BIA - Support  
ACCOC - Oppose

**SB 9**

**(Atkins D) Housing development: approvals.**

**Last Amend:** 8/16/2021

**Status:** 8/19/2021-From committee: Do pass. (Ayes 12. Noes 1.) (August 19).

**Is Fiscal:** Y

**Location:** 6/22/2021-A. APPR.

Desk	Policy	Fiscal	Floor	Desk	Policy	Fiscal	Floor	Conf. Conc.	Enrolled	Vetoed	Chaptered
1st House				2nd House							

**Summary:** The Planning and Zoning Law provides for the creation of accessory dwelling units by local ordinance, or, if a local agency has not adopted an ordinance, by ministerial approval, in accordance with specified standards and conditions. This bill, among other things, would require a proposed housing development containing no more than 2 residential units within a single-family residential zone to be considered ministerially, without discretionary review or hearing, if the proposed housing development meets certain requirements, including, but not limited to, that the proposed housing development would not require demolition or alteration of housing that is subject to a recorded covenant, ordinance, or law that restricts rents to levels affordable to persons and families of moderate, low, or very low income, that the proposed housing development does not allow for the demolition of more than 25% of the existing exterior structural walls, except as provided, and that the development is not located within a historic district, is not included on the State Historic Resources Inventory, or is not within a site that is legally designated or listed as a city or county landmark or historic property or district.

**Notes:** OCCOG - Oppose  
ACCOC - Oppose  
League of California Cities - Oppose  
SCAG - Oppose Unless Amended  
OCBC - Support

**SB 10**

**(Wiener D) Planning and zoning: housing development: density.**

**Last Amend:** 7/5/2021

**Status:** 7/6/2021-Read second time. Ordered to third reading.

**Is Fiscal:** N

**Location:** 7/6/2021-A. THIRD READING

Desk	Policy	Fiscal	Floor	Desk	Policy	Fiscal	Floor	Conf. Conc.	Enrolled	Vetoed	Chaptered
1st House				2nd House							

**Summary:** Would, notwithstanding any local restrictions on adopting zoning ordinances, authorize a local government to adopt an ordinance to zone any parcel for up to 10 units of residential density per parcel, at a height specified in the ordinance, if the parcel is located in a transit-rich area or an urban infill site, as those terms are defined. The bill would prohibit a local government from adopting an ordinance pursuant to these provisions on or after January 1, 2029. The bill would specify that an ordinance adopted under these provisions, and any resolution to amend the jurisdiction's General Plan, ordinance, or other local regulation adopted to be consistent with that ordinance, is not a project for purposes of the California Environmental Quality Act. The bill would prohibit an ordinance adopted under these provisions from superceding a local restriction enacted or approved by a local initiative that designates publicly owned land as open-space land or for park or recreational purposes.

**Notes:**  
OCCOG - Oppose Unless Amended  
ACCOC - Watch  
SCAG - Support If Amended  
OCBC - Support

**SB 12**

**(McGuire D) Local government: planning and zoning: wildfires.**

**Last Amend:** 7/1/2021

**Status:** 7/14/2021-Failed Deadline pursuant to Rule 61(a)(11). (Last location was H. & C.D. on 6/24/2021)(May be acted upon Jan 2022)

**Is Fiscal:** Y

**Location:** 7/14/2021-A. 2 YEAR

Desk	Policy	Fiscal	Floor	Desk	2 year	Fiscal	Floor	Conf. Conc.	Enrolled	Vetoed	Chaptered
1st House				2nd House							

**Summary:** Current law requires that the Office of Planning and Research, among other things, coordinate with appropriate entities, including state, regional, or local agencies, to establish a

clearinghouse for climate adaptation information for use by state, regional, and local entities, as provided. This bill would require the safety element, upon the next revision of the housing element or the hazard mitigation plan, on or after July 1, 2024, whichever occurs first, to be reviewed and updated as necessary to include a comprehensive retrofit strategy to reduce the risk of property loss and damage during wildfires, as specified, and would require the planning agency to submit the adopted strategy to the Office of Planning and Research for inclusion into the above-described clearinghouse.

**Notes:**

OCCOG - Oppose Unless Amended  
 BIA - Oppose Unless Amended  
 OCBC - Oppose Unless Amended

**SB 15**

**(Portantino D) Housing development: incentives: rezoning of idle retail sites.**

**Last Amend:** 5/20/2021

**Status:** 7/14/2021-Failed Deadline pursuant to Rule 61(a)(11). (Last location was DESK on 6/1/2021) (May be acted upon Jan 2022)

**Is Fiscal:** Y

**Location:** 7/14/2021-A. 2 YEAR

Desk	Policy	Fiscal	Floor	2 year	Policy	Fiscal	Floor	Conf. Conc.	Enrolled	Vetoed	Chaptered	
1st House				2nd House								

**Summary:** Current law establishes, among other housing programs, the Workforce Housing Reward Program, which requires the Department of Housing and Community Development to make local assistance grants to cities, counties, and cities and counties that provide land use approval to housing developments that are affordable to very low and low-income households. This bill, upon appropriation by the Legislature in the Budget Act or other act, would require the department to administer a program to provide incentives in the form of grants allocated as provided to local governments that rezone idle sites used for a big box retailer or a commercial shopping center to instead allow the development of housing, as defined.

**Notes:**

OCCOG - Support  
 ACCOC - Support  
 OCBC - Watch  
 SCAG - Support  
 League of California Cities - Support

**SB 44**

**(Allen D) California Environmental Quality Act: streamlined judicial review: environmental leadership transit projects.**

**Last Amend:** 7/14/2021

**Status:** 8/19/2021-August 19 set for first hearing. Placed on suspense file.

**Is Fiscal:** Y

**Location:** 8/19/2021-A. APPR. SUSPENSE FILE

Desk	Policy	Fiscal	Floor	Desk	Policy	Fiscal	Floor	Conf. Conc.	Enrolled	Vetoed	Chaptered	
1st House				2nd House								

**Summary:** Would, until January 1, 2025, establish specified procedures for the administrative and judicial review of the environmental review and approvals granted for an environmental leadership transit project, as defined, proposed by a public or private entity or its affiliates that is located wholly within the County of Los Angeles or connects to an existing project wholly located in that county and that is approved by the lead agency on or before January 1, 2024. The bill would require the project applicant of the environmental leadership transit project to take certain actions in order for those specified procedures to apply to the project. The bill would require the Judicial Council, on or before January 1, 2023, to adopt rules of court establishing procedures requiring actions or proceedings seeking judicial review pursuant to CEQA or the granting of project approvals, including any appeals to the court of appeal or the Supreme Court, to be resolved, to the extent feasible and to the extent prioritizing those actions or proceedings will not exacerbate any civil case backlogs, within 365 calendar days of the filing of the certified record of proceedings with the court to an action or proceeding seeking judicial review of the lead agency's action related to an environmental leadership transit project.

**Notes:**

SCAG - Watch

**SB 45**

**(Portantino D) Wildfire Prevention, Safe Drinking Water, Drought Preparation, and Flood Protection Bond Act of 2022.**

**Last Amend:** 4/8/2021

**Status:** 6/1/2021-Ordered to inactive file on request of Senator Portantino.

**Is Fiscal:** Y

**Location:** 6/1/2021-S. INACTIVE FILE

Desk	Policy	Fiscal	Floor	Desk	Policy	Fiscal	Floor	Conf. Conc.	Enrolled	Vetoed	Chaptered	
1st House				2nd House								

**Summary:** Would enact the Wildfire Prevention, Safe Drinking Water, Drought Preparation, and Flood Protection Bond Act of 2022, which, if approved by the voters, would authorize the issuance of bonds in the amount of \$5,595,000,000 pursuant to the State General Obligation Bond Law to finance projects for a wildfire prevention, safe drinking water, drought preparation, and flood protection program.

**[SB 83](#)**

**(Allen D) Sea Level Rise Revolving Loan Program.**

**Last Amend:** 6/29/2021

**Status:** 7/7/2021-July 7 set for first hearing. Placed on suspense file.

**Is Fiscal:** Y

**Location:** 7/7/2021-A. APPR. SUSPENSE FILE

Desk	Policy	Fiscal	Floor	Desk	Policy	Fiscal	Floor	Conf. Conc.	Enrolled	Vetoed	Chaptered
1st House				2nd House							

**Summary:** Current law establishes in state government the Ocean Protection Council. Current law requires the council to, among other things, establish policies to coordinate the collection, evaluation, and sharing of scientific data related to coastal and ocean resources among agencies. Current law establishes the State Coastal Conservancy with prescribed powers and responsibilities for implementing and administering various programs intended to preserve, protect, and restore the state's coastal areas. This bill would require the council, in consultation with the conservancy, to develop the Sea Level Rise Revolving Loan Program for purposes of providing low-interest loans to local jurisdictions for the purchase of coastal properties in their jurisdictions identified as vulnerable coastal property, as provided.

**[SB 99](#)**

**(Dodd D) Community Energy Resilience Act of 2021.**

**Last Amend:** 7/5/2021

**Status:** 8/19/2021-August 19 set for first hearing. Placed on suspense file.

**Is Fiscal:** Y

**Location:** 8/19/2021-A. APPR. SUSPENSE FILE

Desk	Policy	Fiscal	Floor	Desk	Policy	Fiscal	Floor	Conf. Conc.	Enrolled	Vetoed	Chaptered
1st House				2nd House							

**Summary:** Current law establishes within the Natural Resources Agency the State Energy Resources Conservation and Development Commission. Current law assigns the commission various duties, including applying for and accepting grants, contributions, and appropriations, and awarding grants consistent with the goals and objectives of a program or activity the commission is authorized to implement or administer. This bill, the Community Energy Resilience Act of 2021, would require the commission to develop and implement a grant program for local governments to develop community energy resilience plans and expedite permit review of distributed energy resources by local governments.

**Notes:** League of California Cities - Support

**[SB 214](#)**

**(Bates R) Neighborhood electric vehicles: County of Orange: Ranch Plan Planned Community.**

**Status:** 7/16/2021-Approved by the Governor. Chaptered by Secretary of State. Chapter 101, Statutes of 2021.

**Is Fiscal:** Y

**Location:** 7/16/2021-S. CHAPTERED

Desk	Policy	Fiscal	Floor	Desk	Policy	Fiscal	Floor	Conf. Conc.	Enrolled	Vetoed	Chaptered
1st House				2nd House							

**Summary:** Current law, until January 1, 2022, authorizes the County of Orange to establish a neighborhood electric vehicle (NEV) transportation plan for the Ranch Plan Planned Community in that county. Current law requires the plan to include specified elements, including provisions relating to parking, charging, NEV only lanes, and shared use with conventional vehicle lanes. Current law makes operating a NEV in violation of certain provisions an infraction. This bill would repeal the January 1, 2022, sunset date, thereby indefinitely extending the County of Orange's authority to establish a NEV transportation plan for the Ranch Plan Planned Community.

**Notes:**

OCBC - Support

**[SB 261](#)**

**(Allen D) Regional transportation plans: sustainable communities strategies.**

**Status:** 4/30/2021-Failed Deadline pursuant to Rule 61(a)(2). (Last location was TRANS. on 3/15/2021) (May be acted upon Jan 2022)

**Is Fiscal:** Y

**Location:** 4/30/2021-S. 2 YEAR

Desk	2 year	Fiscal	Floor	Desk	Policy	Fiscal	Floor	Conf. Conc.	Enrolled	Vetoed	Chaptered
1st House				2nd House							

**Summary:** current law requires certain transportation planning agencies to prepare and adopt a regional transportation plan directed at achieving a coordinated and balanced regional transportation system. Certain of these agencies are designated under federal law as metropolitan planning organizations. Existing law requires that each regional transportation plan include a sustainable communities strategy developed to achieve greenhouse gas emission reduction targets for the automobile and light truck sector for 2020 and 2035 established by the State Air Resources Board. This bill would require that the sustainable communities strategy be developed to additionally achieve greenhouse gas emission reduction targets for the automobile and light truck sector for 2045 and 2050 and vehicle miles traveled reduction targets for 2035, 2045, and 2050 established by the board. The bill would make various conforming changes to integrate those additional targets into regional transportation plans.

**Notes:**

OCCOG - Oppose Unless Amended  
 SCAG - Oppose Unless Amended  
 OCTA - Oppose Unless Amended  
 OCBC - Oppose  
 CALCOG - Oppose  
 BIA - Oppose  
 ACCOC - Oppose

**[SB 274](#) (Wieckowski D) Local government meetings: agenda and documents.**

**Last Amend:** 4/5/2021

**Status:** 7/8/2021-Read second time. Ordered to third reading.

**Is Fiscal:** Y

**Location:** 7/8/2021-A. THIRD READING

Desk	Policy	Fiscal	Floor	Desk	Policy	Fiscal	Floor	Conf. Conc.	Enrolled	Vetoed	Chaptered
1st House				2nd House							

**Summary:** The Ralph M. Brown Act requires meetings of the legislative body of a local agency to be open and public and also requires regular and special meetings of the legislative body to be held within the boundaries of the territory over which the local agency exercises jurisdiction, with specified exceptions. Current law authorizes a person to request that a copy of an agenda, or a copy of all the documents constituting the agenda packet, of any meeting of a legislative body be mailed to that person. This bill would require a local agency with an internet website, or its designee, to email a copy of, or website link to, the agenda or a copy of all the documents constituting the agenda packet if the person requests that the items be delivered by email. If a local agency determines it to be technologically infeasible to send a copy of the documents or a link to a website that contains the documents by email or by other electronic means, the bill would require the legislative body or its designee to send by mail a copy of the agenda or a website link to the agenda and to mail a copy of all other documents constituting the agenda packet, as specified.

**Notes:**

OCTA - Neutral  
 Transportation Corridor Agencies - Oppose

**[SB 290](#) (Skinner D) Density Bonus Law: qualifications for incentives or concessions: student housing for lower income students: moderate-income persons and families: local government constraints.**

**Last Amend:** 8/16/2021

**Status:** 8/16/2021-Read third time and amended. Ordered to third reading.

**Is Fiscal:** Y

**Location:** 7/15/2021-A. THIRD READING

Desk	Policy	Fiscal	Floor	Desk	Policy	Fiscal	Floor	Conf. Conc.	Enrolled	Vetoed	Chaptered
1st House				2nd House							

**Summary:** Current law requires the amount of a density bonus and the number of incentives or concessions a qualifying developer receives to be pursuant to a certain formula based on the total number of units in the housing development, as specified. This bill would require a unit designated to satisfy the inclusionary zoning requirements of a city or county to be included in the total number of units on which a density bonus and the number of incentives or concessions are based. The bill would require a city or county to grant one incentive or concession for a student housing development project that will include at least 20% of the total units for lower income students.

**[SB 339](#) (Wiener D) Vehicles: road usage charge pilot program.**

**Last Amend:** 6/14/2021

**Status:** 7/14/2021-July 14 set for first hearing. Placed on suspense file.

**Is Fiscal:** Y

**Location:** 7/14/2021-A. APPR. SUSPENSE FILE

Desk	Policy	Fiscal	Floor	Desk	Policy	Fiscal	Floor	Conf. Conc.	Enrolled	Vetoed	Chaptered
1st House				2nd House							

**Summary:** Current law requires the Chair of the California Transportation Commission to create a Road Usage Charge (RUC) Technical Advisory Committee in consultation with the Secretary of Transportation. Under existing law, the purpose of the technical advisory committee is to guide the development and evaluation of a pilot program to assess the potential for mileage-based revenue collection as an alternative to the gas tax system. Current law requires the technical advisory committee to study RUC alternatives to the gas tax, gather public comment on issues and concerns related to the pilot program, and make recommendations to the Secretary of Transportation on the design of a pilot program, as specified. Current law repeals these provisions on January 1, 2023. This bill would extend the operation of these provisions until January 1, 2027.

**Notes:**

OCTA - Support  
CALCOG - Support

**[SB 342](#) (Gonzalez D) South Coast Air Quality Management District: board membership.**

**Last Amend:** 5/26/2021

**Status:** 6/4/2021-Failed Deadline pursuant to Rule 61(a)(8). (Last location was INACTIVE FILE on 6/3/2021)(May be acted upon Jan 2022)

**Is Fiscal:** N

**Location:** 6/4/2021-S. 2 YEAR

Desk	Policy	Fiscal	2 year	Desk	Policy	Fiscal	Floor	Conf. Conc.	Enrolled	Vetoed	Chaptered
1st House				2nd House							

**Summary:** Current law establishes the South Coast Air Quality Management District vested with the authority to regulate air emissions from stationary sources located in the South Coast Air Basin and establishes a district board, consisting of 13 members. This bill would add 2 members to the district board, appointed by the Senate Committee on Rules and the Speaker of the Assembly. The bill would require the 2 additional members to reside in and work directly with communities in the South Coast Air Basin that are disproportionately burdened by and vulnerable to high levels of pollution and issues of environmental justice. The bill would also require a candidate for these positions to meet other specified requirements.

**Notes:**

OCBC - Oppose

**[SB 477](#) (Wiener D) General plan: annual report.**

**Last Amend:** 6/24/2021

**Status:** 8/19/2021-August 19 set for first hearing. Placed on suspense file.

**Is Fiscal:** Y

**Location:** 8/19/2021-A. APPR. SUSPENSE FILE

Desk	Policy	Fiscal	Floor	Desk	Policy	Fiscal	Floor	Conf. Conc.	Enrolled	Vetoed	Chaptered
1st House				2nd House							

**Summary:** The Planning and Zoning Law requires a city or county to adopt a general plan for land use development within its boundaries that includes, among other things, a housing element. That law requires the planning agency of a city or county to provide, by April 1 of each year, an annual report to, among other entities, the Department of Housing and Community Development that includes, among other specified information, the number of applications submitted, the location and total number of developments approved, the number of building permits issued, and the number of units constructed pursuant to a specific streamlined, ministerial approval process. This bill would, commencing January 1, 2024, require a planning agency to include in that annual report specified information on costs, standards, and applications for proposed housing development projects and specified information on housing development projects within the jurisdiction.

**[SB 478](#) (Wiener D) Planning and Zoning Law: housing development projects.**

**Last Amend:** 7/5/2021

**Status:** 8/19/2021-August 19 set for first hearing. Placed on suspense file.

**Is Fiscal:** Y

**Location:** 8/19/2021-A. APPR. SUSPENSE FILE

Desk	Policy	Fiscal	Floor	Desk	Policy	Fiscal	Floor	Conf. Conc.	Enrolled	Vetoed	Chaptered
1st House				2nd House							

**Summary:** The Planning and Zoning Law requires the Department of Housing and Community Development to notify the city, county, or city and county, and authorizes the department to notify the Attorney General, that the city, county, or city and county is in violation of state law if the department finds that the housing element or an amendment to that element, or any specified action or failure to act, does not substantially comply with the law as it pertains to housing elements or that any local government has taken an action in violation of certain housing laws. This bill would prohibit a local agency, as defined, from imposing a floor-to-area ratio standard that is less than 1.0 on a housing development project that consists of 3 to 7 units, or less than 1.25 on a housing development project

that consists of 8 to 10 units. The bill would prohibit a local agency from imposing a lot coverage requirement that would physically preclude a housing development project from achieving the floor-to-area ratios described above.

**Notes:**

OCCOG - Oppose

ACCOC - Oppose

**SB 581**

**(Atkins D) General plan.**

**Status:** 7/1/2021-Read second time. Ordered to consent calendar. Ordered to inactive file on request of Assembly Member Chau.

**Is Fiscal:** Y

**Location:** 7/1/2021-A. INACTIVE FILE

Desk	Policy	Fiscal	Floor	Desk	Policy	Fiscal	Floor	Conf. Conc.	Enrolled	Vetoed	Chaptered
1st House				2nd House							

**Summary:** The Planning and Zoning Law, requires a city or county to adopt a general plan for land use development within its boundaries that includes, among other things, a housing element. That law requires the planning agency of a city or county to provide by April 1 of each year an annual report to, among other entities, the Department of Housing and Community Development. The law requires that the annual report include, among other specified information, the number of housing development applications received and the number of units approved and disapproved in the prior year. This bill would additionally require the planning agency include in the annual report whether the city or county is a party to a court action related to a violation of state housing law, and the disposition of that action.

**SB 582**

**(Stern D) Climate Emergency Mitigation, Safe Restoration, and Just Resilience Act of 2021.**

**Last Amend:** 5/20/2021

**Status:** 6/4/2021-Failed Deadline pursuant to Rule 61(a)(8). (Last location was INACTIVE FILE on 6/3/2021)(May be acted upon Jan 2022)

**Is Fiscal:** Y

**Location:** 6/4/2021-S. 2 YEAR

Desk	Policy	Fiscal	2 year	Desk	Policy	Fiscal	Floor	Conf. Conc.	Enrolled	Vetoed	Chaptered
1st House				2nd House							

**Summary:** Would require the State Air Resources Board to ensure that statewide greenhouse gas emissions are reduced to at least 40% and up to 80% below the 1990 level by 2030. By expanding the scope of a crime, this bill would imposed a state-mandated local program. The bill would adopt a state policy to lead a global effort to restore oceanic and atmospheric concentrations of greenhouse gas emissions to preindustrial levels as soon as possible to secure a safe climate for all, and to restore community health and reverse the impacts from the damage and injustice climate change is causing to the people, the economy, and the environment of California. The bill would require the Secretary of the Natural Resources Agency, in coordination with the Secretary for Environmental Protection and the State Air Resources Board, and concurrent with the scoping plan, to develop a climate restoration plan that specifies carbon removal targets, before 2035, as necessary to facilitate achievement of those goals.

**Notes:**

OCBC - Oppose

**SB 623**

**(Newman D) Electronic toll and transit fare collection systems.**

**Status:** 4/30/2021-Failed Deadline pursuant to Rule 61(a)(2). (Last location was JUD. on 4/13/2021) (May be acted upon Jan 2022)

**Is Fiscal:** Y

**Location:** 4/30/2021-S. 2 YEAR

Desk	2 year	Fiscal	Floor	Desk	Policy	Fiscal	Floor	Conf. Conc.	Enrolled	Vetoed	Chaptered
1st House				2nd House							

**Summary:** Current law requires the Department of Transportation, in cooperation with the Golden Gate Bridge, Highway and Transportation District and all known entities planning to implement a toll facility, to develop and adopt functional specifications and standards for an automatic vehicle identification system in compliance with specified objectives, and generally requires any automatic vehicle identification system purchased or installed after January 1, 1991, to comply with those specifications and standards. Current law authorizes operators of toll facilities on federal-aid highways engaged in an interoperability program to provide only specified information regarding a vehicle's use of the toll facility. This bill would authorize those operators to provide instead only the information specified in functional specifications and standards adopted by the department and operators of toll facilities in this state on federal-aid highways for purposes of interstate interoperability.

**Notes:**

OCCOG - Support



OCTA - Support  
 OCBC - Support  
 TCA - Support  
 SCAG - Support

**SB 640 (Becker D) Transportation financing: jointly funded projects.**

**Last Amend:** 5/20/2021

**Status:** 7/16/2021-Approved by the Governor. Chaptered by Secretary of State. Chapter 108, Statutes of 2021.

**Is Fiscal:** Y

**Location:** 7/16/2021-S. CHAPTERED

Desk	Policy	Fiscal	Floor	Desk	Policy	Fiscal	Floor	Conf. Conc.	Enrolled	Vetoed	Chaptered
1st House				2nd House							

**Summary:** Current law provides for the deposit of various funds, including revenues from certain increases in fuel taxes and vehicle fees, for the program into the Road Maintenance and Rehabilitation Account. After certain allocations for the program are made, existing law requires the remaining funds available for the program to be continuously appropriated 50% for allocation to the department for maintenance of the state highway system or for the State Highway Operation and Protection Program and 50% for apportionment to cities and counties by the Controller pursuant to a specified formula. Current law requires a city or county to submit to the California Transportation Commission a list of proposed projects, as specified, to be eligible for an apportionment of those funds. This bill would authorize cities and counties to propose projects to be jointly funded by the cities and counties' apportionments of those funds, as specified.

**Notes:**

League of California Cities - Support  
 OCTA - Support

**SB 649 (Cortese D) Local governments: affordable housing: local tenant preference.**

**Last Amend:** 4/19/2021

**Status:** 6/17/2021-Re-referred to Com. on RLS. pursuant to Assembly Rule 96.

**Is Fiscal:** N

**Location:** 6/17/2021-A. RLS.

Desk	Policy	Fiscal	Floor	Desk	Policy	Fiscal	Floor	Conf. Conc.	Enrolled	Vetoed	Chaptered
1st House				2nd House							

**Summary:** Would establish a state policy supporting local tenant preferences for lower income households, as defined, that are subject to displacement risk, and, further, permit local governments and developers in receipt of local or state funds, federal or state tax credits, or an allocation of tax-exempt private activity bonds designated for affordable rental housing to restrict occupancy by creating a local housing preference for lower income households subject to displacement risk. The bill, subject to certain requirements and limitations, would authorize a local government to allow a local tenant preference in an affordable housing rental development to reduce displacement of lower income households with displacement risk beyond local government boundaries by adopting a program that allows preferences in affordable rental housing acquired, constructed, preserved or funded with state or local funds or tax programs.

**SB 671 (Gonzalez D) Transportation: Clean Freight Corridor Efficiency Assessment.**

**Last Amend:** 6/15/2021

**Status:** 8/19/2021-August 19 set for first hearing. Placed on suspense file.

**Is Fiscal:** Y

**Location:** 8/19/2021-A. APPR. SUSPENSE FILE

Desk	Policy	Fiscal	Floor	Desk	Policy	Fiscal	Floor	Conf. Conc.	Enrolled	Vetoed	Chaptered
1st House				2nd House							

**Summary:** Would establish the Clean Freight Corridor Efficiency Assessment, to be developed by the California Transportation Commission, in coordination with other state agencies. In developing the assessment, the bill would require the commission to identify freight corridors, or segments of corridors, throughout the state that would be priority candidates for the deployment of zero-emission medium- and heavy-duty vehicles. The bill would require the commission to submit a report containing the assessment's findings and recommendations to certain committees of the Legislature by December 1, 2023. The bill would require the assessment's findings and recommendations to be incorporated into the development of the California Transportation Plan. The bill would require the state freight plan to include a description of needed infrastructure, projects, and operations for the deployment of zero-emission medium- and heavy-duty vehicles and the development of freight corridors identified in the assessment.

**SB 726 (Gonzalez D) Alternative fuel and vehicle technologies: Sustainable Transportation Strategy.**

**Last Amend:** 6/29/2021

**Status:** 8/19/2021-August 19 set for first hearing. Placed on suspense file.

**Is Fiscal:** Y

**Location:** 8/19/2021-A. APPR. SUSPENSE FILE

Desk	Policy	Fiscal	Floor	Desk	Policy	Fiscal	Floor	Conf. Conc.	Enrolled	Vetoed	Chaptered
1st House				2nd House							

**Summary:** Would require the State Air Resources Board and the State Energy Resources Conservation and Development Commission, in coordination with specified public agencies, including local air pollution control districts and air quality management districts, if those districts choose to participate, to jointly develop, no later than January 1, 2024, a comprehensive transportation sustainability strategy to be known as the Sustainable Transportation Strategy. The bill would specify that the purpose of the strategy is to evaluate the plans, actions, and required funding needed to reach the state's various transportation greenhouse gas emissions and criteria pollutant reduction goals in a cost-effective, technology neutral, and efficient manner, specifically considering the role of sustainable transportation goals and programs.

**[SB 728](#) ([Hertzberg D](#)) **Density Bonus Law: purchase of density bonus units by nonprofit housing organizations.****

**Last Amend:** 4/15/2021

**Status:** 8/19/2021-From consent calendar on motion of Assembly Member Reyes. Ordered to third reading.

**Is Fiscal:** Y

**Location:** 8/19/2021-A. THIRD READING

Desk	Policy	Fiscal	Floor	Desk	Policy	Fiscal	Floor	Conf. Conc.	Enrolled	Vetoed	Chaptered
1st House				2nd House							

**Summary:** Current law, commonly referred to as the Density Bonus Law, requires a city or county to provide a developer that proposes a housing development within the city or county with a density bonus and other incentives or concessions, as specified, if the developer agrees to construct, among other options, specified percentages of units for moderate-income or, lower, or very low income households and meets other requirements. Current law requires the developer and the city or county to ensure that the initial occupant of a for-sale unit that qualified the developer for the award of the density bonus is a person or family of very low, low, or moderate income. This bill, as an alternative to ensuring that the initial occupant of a for-sale unit is a person or family of the required income, would authorize the developer and the city or county to ensure that a qualified nonprofit housing organization that is receiving the above-described welfare exemption purchases the unit pursuant to a specified recorded contract that includes an affordability restriction, an equity sharing agreement, and a repurchase option that requires a subsequent purchaser that desires to sell or convey the property to first offer the nonprofit corporation the opportunity to repurchase the property.

**[SB 765](#) ([Stern D](#)) **Accessory dwelling units: setbacks.****

**Status:** 4/30/2021-Failed Deadline pursuant to Rule 61(a)(2). (Last location was HOUSING on 3/3/2021)(May be acted upon Jan 2022)

**Is Fiscal:** Y

**Location:** 4/30/2021-S. 2 YEAR

Desk	2 year	Fiscal	Floor	Desk	Policy	Fiscal	Floor	Conf. Conc.	Enrolled	Vetoed	Chaptered
1st House				2nd House							

**Summary:** The Planning and Zoning Law, among other things, provides for the creation of accessory dwelling units by local ordinance, or, if a local agency has not adopted an ordinance, by ministerial approval, in accordance with specified standards and conditions. Current law prohibits a local agency's accessory dwelling unit ordinance from imposing a setback requirement of more than 4 feet from the side and rear lot lines for an accessory dwelling unit that is not converted from an existing structure or a new structure constructed in the same location and to the same dimensions as an existing structure. This bill would remove the above-described prohibition on a local agency's accessory dwelling unit ordinance, and would instead provide that the rear and side yard setback requirements for accessory dwelling units may be set by the local agency. The bill would authorize an accessory dwelling unit applicant to submit a request to the local agency for an alternative rear and side yard setback requirement if the local agency's setback requirements make the building of the accessory dwelling unit infeasible.

**Notes:**

OCCOG - Support  
League of California Cities - Support

**[SB 778](#) ([Becker D](#)) **Buy Clean California Act: Environmental Product Declarations: concrete.****

**Last Amend:** 6/21/2021

**Status:** 7/14/2021-Failed Deadline pursuant to Rule 61(a)(11). (Last location was A. & A.R. on 6/24/2021)(May be acted upon Jan 2022)

**Is Fiscal:** Y

**Location:** 7/14/2021-A. 2 YEAR

Desk	Policy	Fiscal	Floor	Desk	2 year	Fiscal	Floor	Conf.	Enrolled	Vetoed	Chaptered	
1st House				2nd House				Conc.				

**Summary:** Would require as part of the Buy Clean California Act, beginning July 1, 2022, an awarding authority to require a successful bidder for a contract for an eligible project, as separately defined for purposes of these requirements, to submit a current Environmental Product Declaration, as defined, for each concrete product before the product is installed in the project, as provided. The bill would require the awarding authority, beginning January 1, 2023, when letting contracts that include concrete for use in an eligible project to require all bids to include the global warming potential, as defined, for each concrete product that will be delivered, the total concrete production CO2e, as defined, for all concrete products included in the bid, and an estimate of delivery emissions, as defined, from transporting the concrete. The bill would require the State Air Resources Board, on or before January 1, 2024, to establish, and the department to publish in the State Contracting Manual, in a department management memorandum, or on the department's internet website, the maximum global warming potential for concrete at the industry average global warming potential for concrete within each project region and performance class, as provided.

**SCA 2**

**(Allen D) Public housing projects.**

**Status:** 7/15/2021-July 15 hearing: Placed on APPR suspense file.

**Is Fiscal:** N

**Location:** 7/15/2021-S. APPR. SUSPENSE FILE

Desk	Policy	Fiscal	Floor	Desk	Policy	Fiscal	Floor	Conf.	Enrolled	Vetoed	Chaptered	
1st House				2nd House				Conc.				

**Summary:** The California Constitution prohibits the development, construction, or acquisition of a low-rent housing project, as defined, in any manner by any state public body until a majority of the qualified electors of the city, town, or county in which the development, construction, or acquisition of the low-rent housing project is proposed approve the project by voting in favor at an election, as specified. This measure would repeal these provisions.

**Notes:**

SCAG - Support

**Total Measures: 76**

**Total Tracking Forms: 76**



## AGENDA ITEM # 8

## Regional Early Action Planning (REAP) Subregional Partners Program Grant Update

### STAFF RECOMMENDATION

Receive and file.

### SUMMARY

OCCOG is receiving \$3.245M in suballocated funds from the Southern California Association of Governments (SCAG) as part of the Subregional Partners Program of the Regional Early Action Planning (REAP) Grant Program. The Board has previously approved a program of projects to support our member jurisdictions in developing their housing elements and completing other planning activities related to increasing the amount of housing that is able to be built in Southern California. Staff is providing an update today on the progress of these projects.

### BACKGROUND

OCCOG has four projects that we submitted with our application for the REAP program. Two projects are supporting the Orange County Housing Trust and Orange County Housing Finance Trust. OCCOG will provide an update on those projects next month. Today's update will focus on the two projects we are managing directly.

#### Geospatial Planning Solutions and 3-D Site Visualization

- RFP released
- Consultant selected February 25, 2021
- WSP and Esri providing these services and work has been progressing swiftly
- WSP has conducted surveys and focus groups with OCCOG jurisdictions
- Conducting biweekly progress meetings with WSP, Esri and OCCOG team
- Funds for Phase 2 were delayed somewhat and that resulted in adjustments to the initial timeline for final deliverables.
- 3-D Site visualization services are available anytime until June 2023.
- Reminder: Each jurisdiction receives a custom 3-D site visualization using Unreal Engine AND training for staff to use the "self-serve" site visualization tool, with license that is provided via this contract.



### Housing Production Planning Activities

- Includes housing video series, ADU How-To Toolkit, Housing OC website, pre-approved plans and specifications, on-call staff augmentation, and model ordinance development
- OCCOG is handling the housing video production, ADU how-to Toolkit and website design and development with our contract staff
  - One housing video, with Spanish translation released per month.
  - Available to OCCOG jurisdictions for their use via OCCOG website.
  - Includes snackable content for social media.
  - 4 videos produced so far.
- Initial plan for pre-approved ADU plans and specifications was modified based on feedback from OCCOG jurisdictions
  - Moved away from procuring consultant for developing plans and specs
  - Instead, provide a clearinghouse for plans/specs already available
  - Work with building departments on securing approvals for plans and specs already procured via SCAG and other jurisdictions.
  - Interactive data-driven website that will enable property owners to see what plans are available at their address. Checklist that will help simplify the ADU permitting process. Vendor portal including financing, contractors, designers/architects.
- We are in discussions with Ventura County Council of Governments and Gateway Cities Council of Governments who were each planning similar projects to OCCOG's planned project
  - Jointly work together on a new approach to ADU pre-approved plans and specifications, a housing resource website and model ordinance development.
  - MOUs in development now, will bring to Board in October for review and approval.
  - Each COG will bring REAP funding to the table.
  - Opportunity for already-budgeted OCCOG staff time to be funded in part by contributions from the partners, allowing us to stretch our REAP dollars further.
  - SCAG to provide access to their already procured bench of consultants to shorten procurement time and provide invoicing support, easing some administrative burden on OCCOG. Will be offset by some of our REAP funds being used for administration.

### STAFF CONTACT

Marnie O. Primmer  
OCCOG Executive Director  
(949)216-5288  
marnie@occog.com

The image shows three electric vehicle charging stations in a row, set against a background of green bushes and trees. Each station consists of a black vertical post with a charging cable coiled around it. The cables are black with a blue and white charging head. The text "Charge Ready" is overlaid in white, sans-serif font on the right side of the image.

Charge Ready

# Program Highlights

- \$436M program to support EV charging infrastructure for light-duty electric vehicles
- Expansion of the Charge Ready Pilot
- Provides significant financial and technical assistance to install charging stations
- Authorized budget will support ~38,000 charging ports
- Three program offerings with incentive options

# Charge Ready Program Offerings

	1 MAKE-READY EXPANSION	2 OWN & OPERATE	3 NEW CONSTRUCTION REBATE
Objective	Provide <b>make-ready infrastructure</b> for EV charging to commercial and multifamily sites	Provide <b>full turnkey solution</b> to multifamily properties in DACs	Incentivize multifamily developers to install charging stations at <b>new construction projects</b>
Target Customers	Existing <b>commercial, government including fleets, and multifamily</b> properties.	<b>Multifamily properties</b> located in DACs	<b>New construction multifamily properties</b>
Offering	Covers <b>make-ready infrastructure</b> up to EVSE stub-out - AND - <b>EVSE rebate</b> to help offset equipment and installation costs	Covers <b>make-ready infrastructure and EVSE</b> —owned and operated by SCE - OR - Customers can choose to own EVSE and receive a <b>rebate on EVSE, maintenance, and networking</b>	<b>\$3,500 per port</b> to help offset charging station and infrastructure costs
Program Targets	<ul style="list-style-type: none"> <li>~19,500 Level 1 or 2 ports and ~200 DCFC ports (DCFC available 2022)</li> <li>50% ports in DAC</li> <li>30% ports at multifamily</li> </ul>	Up to 2,500 Level 1 or 2 ports	<ul style="list-style-type: none"> <li>Up to ~15,000 Level 1 or 2 ports</li> <li>50% ports in DAC</li> </ul>



# SCE's "Make-Ready" Model

## SCE-BUILT MAKE-READY INFRASTRUCTURE

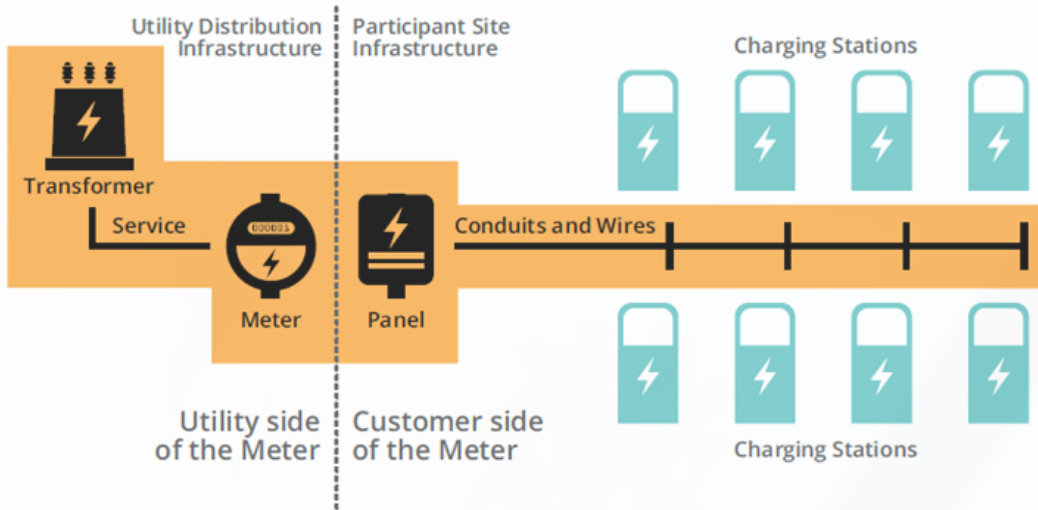

Program covers costs associated with service drop, meter, panel and circuit dedicated to EV charging. Make-Ready ends at interconnection point with customer charging equipment providing AC service.

## CUSTOMER-BUILT PORTION MAKE-READY INFRASTRUCTURE

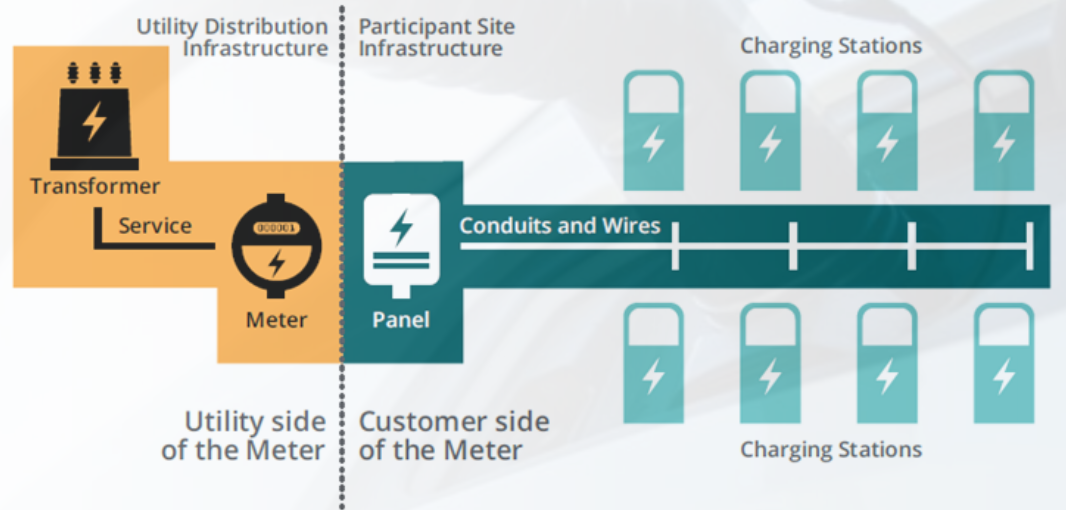

Program covers costs associated with service drop, meter, SCE infrastructure ends at interconnection point with customer provided panel.  
Customer will provide panel and construct all conduits and wires leading to interconnection point with charging equipment.

# Charge Ready Key Program Requirements

## APPLICANT ROLE

- **Non-residential** SCE customer
- **Own, lease, manage**, or be the customer of record of charging site
- Obtain **consent from property owner**
- Grant **easement rights** to SCE
- Project site must be **located in SCE service area**

## DEPLOYMENT

- **Minimum of four** Level 1 or Level 2 charging ports
- **Minimum of two DCFC** charging ports, if installing DCFC (not currently available)
- DCFC must be **publicly accessible**
- All charging equipment must be **separately metered**
- Enroll in a **demand response program**

## EQUIPMENT

- Select from **SCE's approved product list** to qualify for the rebate
- Keep equipment **operational for 10 years**
- Provide **monthly charging data**
- Report **prices charged** to EV drivers

# PROP 1 IRWM ROUND 2 GRANT - SANTA ANA RIVER WATERSHED -



Santa Ana Watershed Project Authority  
11615 Sterling Avenue  
Riverside, CA 92503  
[www.sawpa.org](http://www.sawpa.org)

Orange County Watersheds  
2301 N. Glassell Street  
Orange, CA 92865  
[www.ocwatersheds.com](http://www.ocwatersheds.com)



# CALIFORNIA INTEGRATED REGIONAL WATER MANAGEMENT (IRWM) PROGRAM

- There are 12 IRWM Funding Areas across the State,
- The Santa Ana (River Watershed) Funding Area is covered under the One Water One Watershed IRWM Program,
  - SAWPA facilitates the IRWM planning and grant funding process through the OWOW Program.
  - Projects seeking funding for the \$7.18 Million designated for North and Central Orange County will need to apply through the OC Plan process, which will include a similar schedule as the OWOW process.

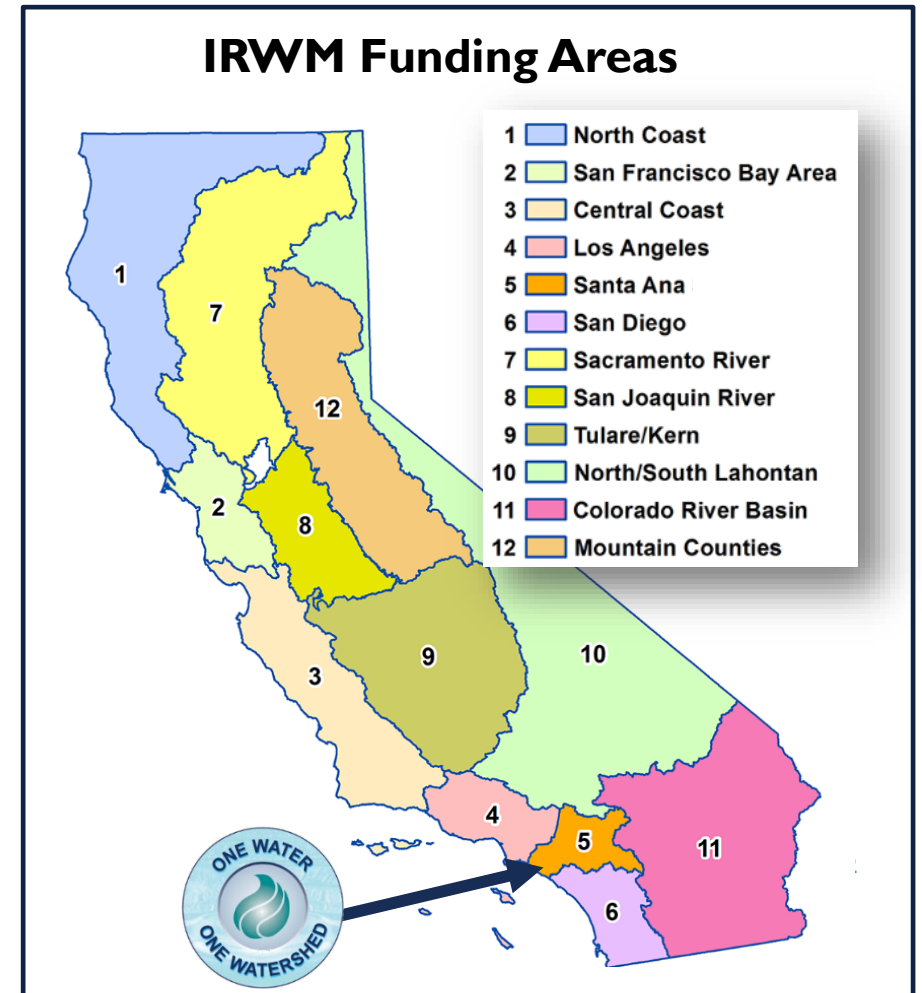

# Santa Ana River Watershed Location

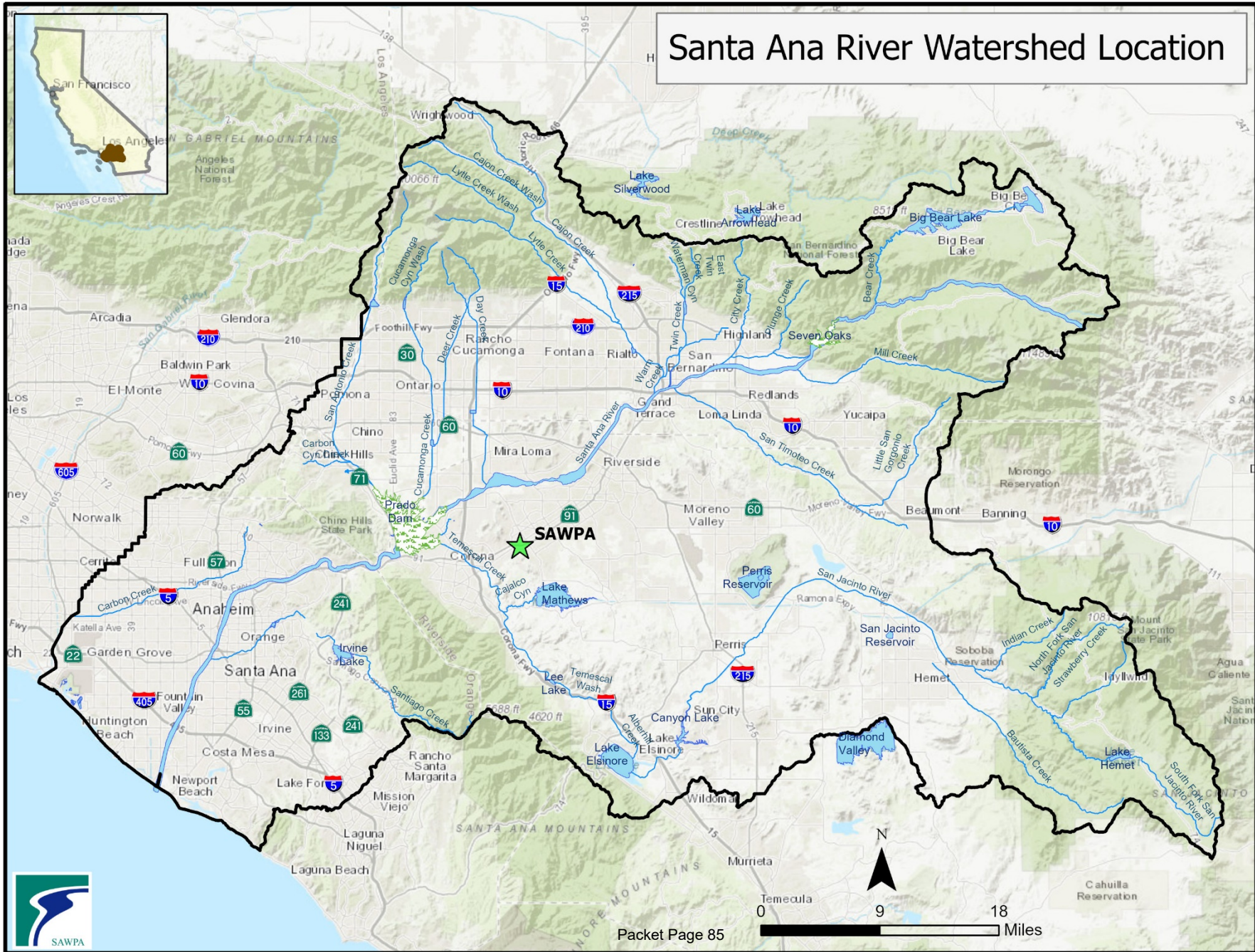

# AVAILABLE FUNDING THROUGH PROPOSITION 1 ROUND 2

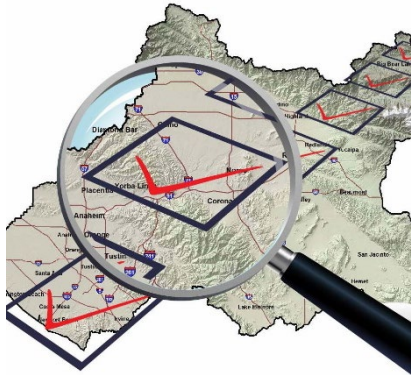

- Proposition 1, passed in 2014, had \$63 million IRWM funding designation for Santa Ana River Watershed.
- 50% cost share required.
- Department of Water Resources (DWR), which manages the State-wide IRWM grant funding program, will likely release the Proposal Solicitation Package (PSP) for Prop 1 Round 2 IRWM Implementation grants in August 2021.

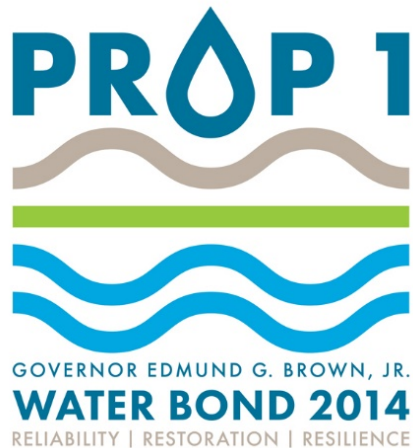

# PROP 1 ROUND 2 FUNDING AVAILABLE IN WATERSHED

- Total of approximately \$27 million available in Round 2.
- There are several funding categories created by 2019 agreement with North Orange County IRWM group.

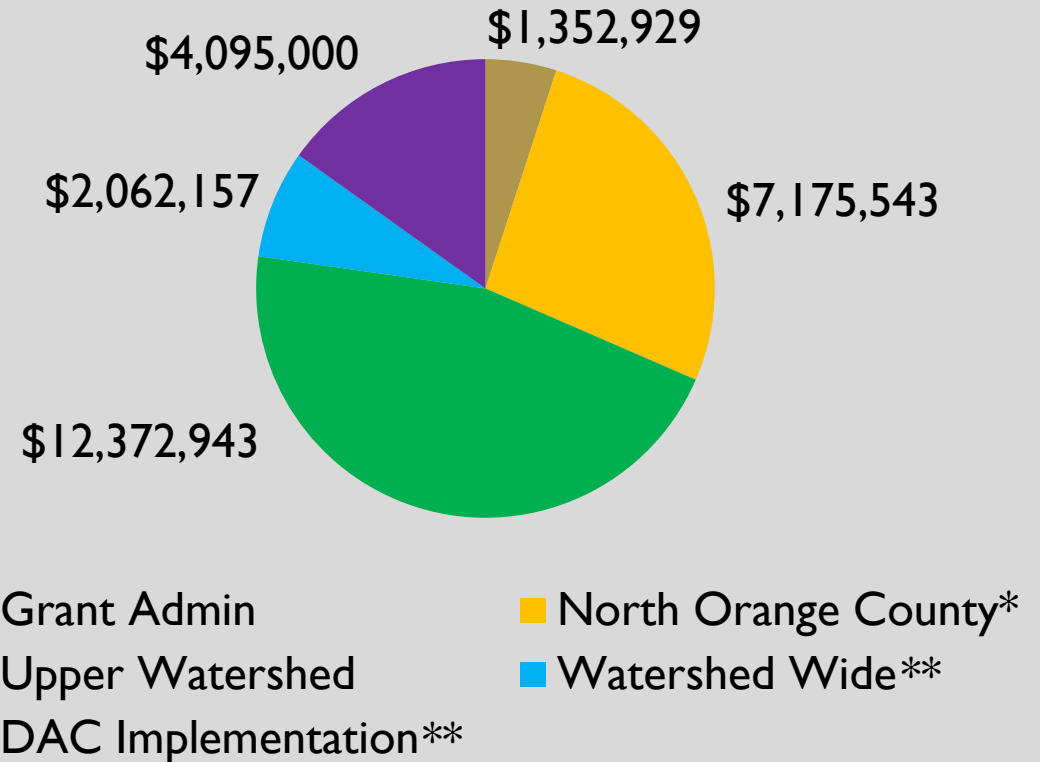

Total in Pie Chart = \$27,058,572

\*Includes \$989,072 carry over from Round 1. North OC also able to receive some/all of the “Watershed Wide” amount.  
\*\*North OC entities also eligible to apply for this funding.

# ELIGIBLE PROJECTS

## Major project eligibility criteria:

- Respond to climate change,
- Contribute to regional water self-reliance, and
- Include multiple and quantifiable benefits.

Note that projects that meet the criteria above and also benefit disadvantaged communities (DACs)\* have access to \$4.1 million and waiver of some/all of 50% required cost share.

## Eligible lead applicants:

- Public Agencies,
- Non-profit Organizations,
- Public Utilities,
- Federally Recognized Indian Tribes,
- California Native American Tribes, and
- Mutual Water Companies.

\*DACs defined as “a community with an annual median household income that is less than 80% of the statewide annual median household income.”



# OWOW - HOW TO APPLY

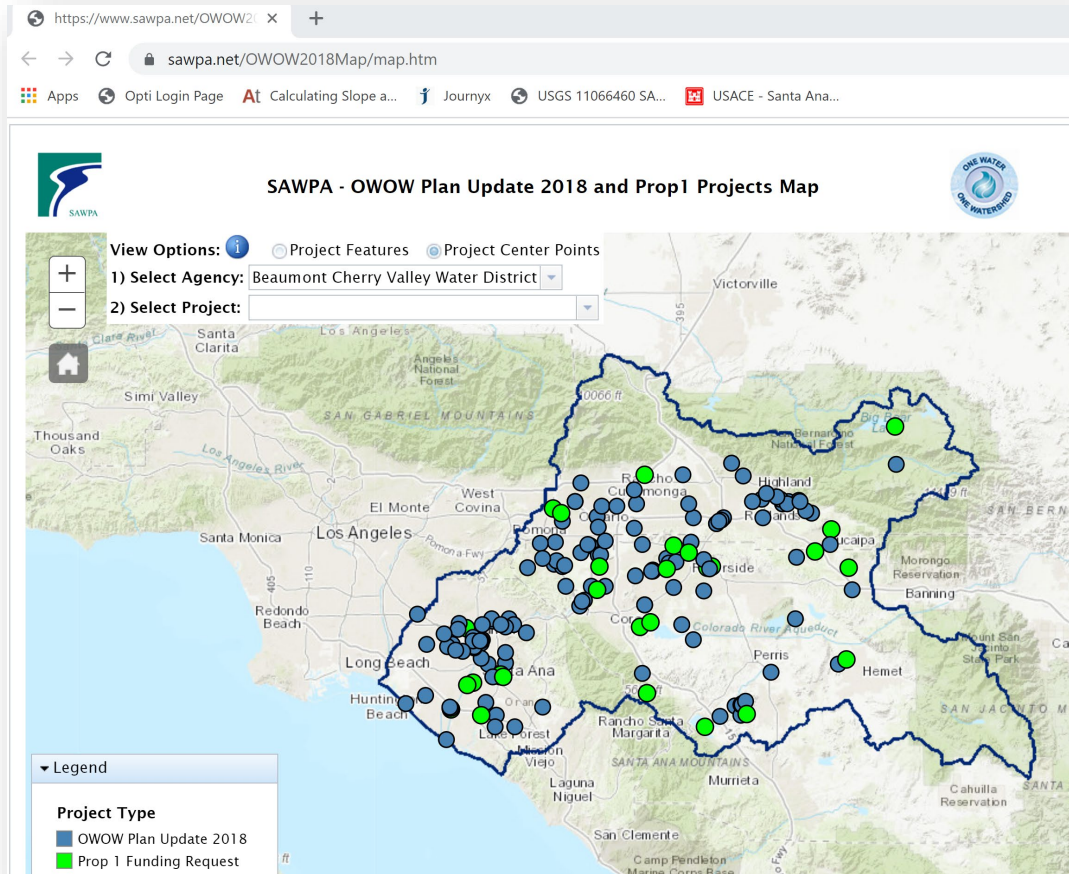

- Attend OWOW workshops held this year by signing up via the OWOW email list on the SAWPA webpage [www.sawpa.org/owow/future-funding-opportunities/](http://www.sawpa.org/owow/future-funding-opportunities/).
- When the OWOW Call for Projects starts in Fall 2021, submit a project(s) via the SAWPA webpage listed above.
- After your submission, you will be asked to participate in a “Participatory Budgeting” process beginning in early 2022.
- If selected, you will work with SAWPA to draft a final grant application to DWR in mid-2022.



\*North OC entities also eligible to apply for watershed-wide and DAC funding via OWOW Call for Projects.

# OC PLAN - OVERVIEW

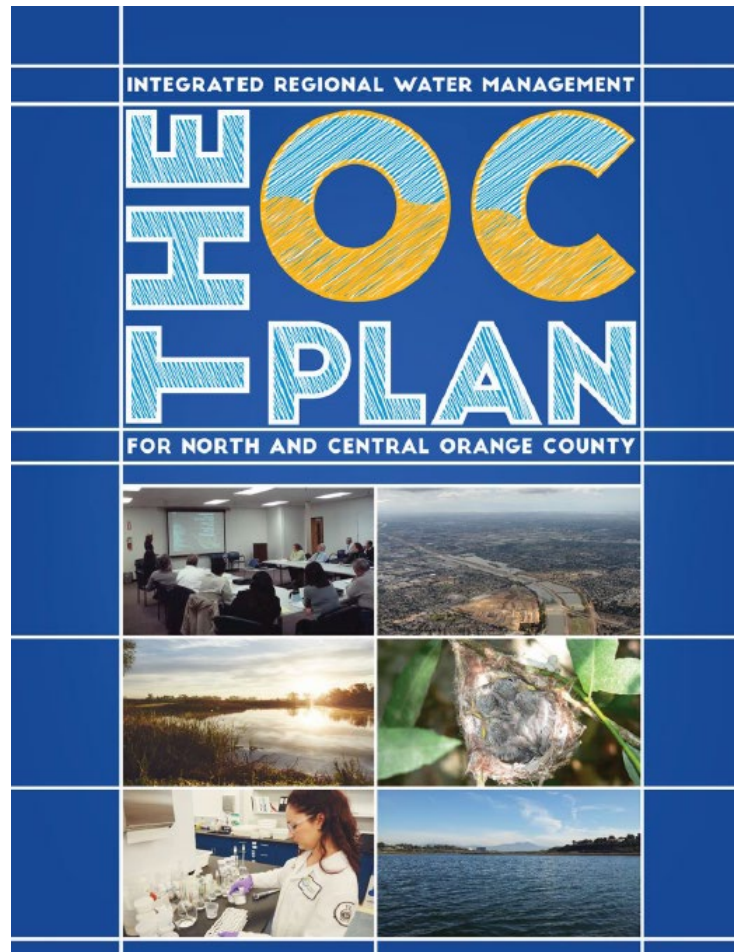

- Stakeholder-driven update to previous IRWM plans for North and Central Orange County
- Completed March 2018
- OC Plan goals / regional priorities:
  - Provide adequate and reliable water supplies
  - Protect and enhance water quality
  - Integrate flood management
  - Restore ecosystems & improve native habitat
  - Improve quality of life in Orange County
  - Address climate change

# OC PLAN - HOW TO APPLY

**Project Submittal Form**

This form will assist you in submitting your project. In order to qualify for IRWM Grant funds, your project must be included on the prioritized IRWM Project List. If your project includes stormwater or dry weather runoff capture, your project must also be included on the prioritized OC SWRP Project List. The following questions will guide you through submitting your project to the IRWM and the OC SWRP Project Lists. All questions are required unless marked as (optional). Please note that we've merged the online submittal forms for the IRWM and OC SWRP Project Lists to simplify the process for project proponents needing to submit to both plans. Your project, once submitted will be on both applicable lists, or just the applicable IRWM list, should that be your intent. If you have any questions, please use the "Contact Us" button at the bottom of the page.

Are you updating information for a previously submitted project?

Select... ▾

Please select a location for your project by clicking on the map below.

No location selected Reset

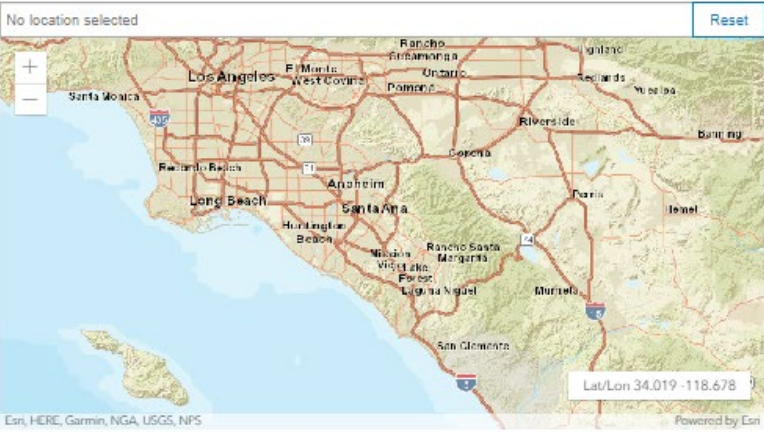

Esri, HERE, Garmin, NGA, USGS, NPS  
Powered by Esri

Next

- When the OC Plan Call for Projects starts in Fall / Winter 2021, submit a project(s) via the Project Submittal Form at [www.northocirwm.org](http://www.northocirwm.org)
- Project prioritization is determined by a number of factors and based on information provided in the Project Submittal Form
  - Collaborative, multi-benefit projects score highest
- If selected, you will work with SAWPA to draft a final grant application to DWR in mid-2022
- Please contact Christy Suppes at [Christy.suppes@ocpw.ocgov.com](mailto:Christy.suppes@ocpw.ocgov.com) for more information and/or to be included on the OC Plan distribution list

# SOUTH ORANGE COUNTY

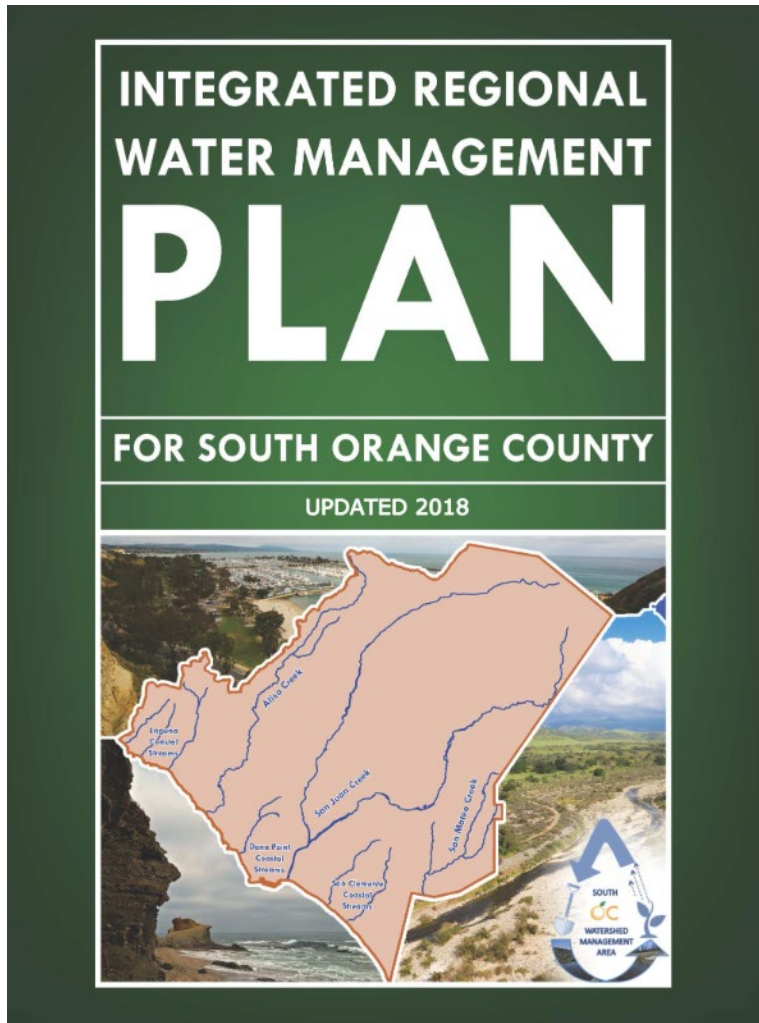

- South Orange County is within the San Diego Funding Area, and receive a separate allocation of funding
- Please contact Jenna Voss at [jenna.voss@ocpw.ocgov.com](mailto:jenna.voss@ocpw.ocgov.com) for information about the IRWM Plan for South Orange County and the Proposition 1, Round 2 Call for Projects



MARK NORTON

SAWPA WATER RESOURCES & PLANNING MANAGER

[MNORTON@SAWPA.ORG](mailto:MNORTON@SAWPA.ORG)

(951) 354-4221



IAN ACHIMORE

SAWPA SENIOR WATERSHED MANAGER

[IACHIMORE@SAWPA.ORG](mailto:IACHIMORE@SAWPA.ORG)

(951) 354-4233

[WWW.SAWPA.ORG/OWOW/FUTURE-FUNDING-OPPORTUNITIES](http://WWW.SAWPA.ORG/OWOW/FUTURE-FUNDING-OPPORTUNITIES)

# QUESTIONS AND OWOW CONTACTS

